

# GO REGULATOR

## PR-59 Series

High Pressure/High Flow Pressure Reducing Regulator



Designed for low and high pressures up to 4000 psig inlet, the PR-59 Series pressure reducing regulator controls high flow with its Cv flow coefficient of 1.2. Though normally supplied without self-relieving capability, this feature can be added as an option.

While primarily designed for use with gas streams, the PR-59 can be used with virtually any liquid systems that are compatible with the seals. A large size piston sensor gives good sensitivity of control even at low outlet pressures and the Kel-F® valve seat assembly gives normal bubble-tight shutoff.

### Features & Specifications

- 316L stainless steel, brass and Monel® body construction
- Inlet pressure capability up to 4000 psig
- Outlet control ranges from 250 psig up to 4000 psig
- Optional self-relieving feature
- Inlet and outlet ports of ½" or ¾" FNPT with ¼" FNPT gauge ports optional
- Balanced poppet valve design for constant pressure control
- Viton® seals (other elastomers optional)
- PCTFE seat
- Cv flow coefficient is 1.2
- Operating temperatures of -40° F to +175° F (-40° C to +80° C)

pressure regulators

### GO Regulator

405 Centura Court • PO Box 4866 • Spartanburg, SC 29303

Phone (864) 574-7966 Fax (864) 574-5608

www.goreg.com • sales@goreg.com

# PR-59 Series

## How to Order

### PR59 –

#### BODY MATERIAL

- 1 316L stainless steel
- 2 Brass
- 4 Monel®

#### PORT CONFIGURATION

- A Standard

For more port configurations, see page 35

#### PROCESS PORT TYPES

(GAUGE PORT TYPES, IF SPECIFIED)

- 5 ½" FNPT (¼" FNPT gauge ports)
- A ¾" FNPT (¼" tube gauge ports)
- B ¾" ISO-7 parallel (¼" FNPT gauge ports)

#### SURFACE FINISH OF DIAPHRAGM CAVITY

- 1 < 25 Ra

#### SEAT MATERIAL

- H PCTFE (formerly Kel-F® 81)
- I Teflon® (0–1000 psig maximum inlet)

#### FLOW COEFFICIENT (Cv)

- 9 1.2

#### CAP ASSEMBLY

- 1 Standard, stainless steel
- 4 Panel mount, stainless steel
- 5 Captured vent, stainless steel
- 6 Captured vent, panel mount, stainless steel
- 9 Plastic knob, stainless steel
- A Captured vent, plastic knob, stainless steel
- B Panel mount, plastic knob, stainless steel

#### PISTON MATERIAL

- 5 Stainless steel
- B Monel®

#### PISTON TYPE

- 1 Non-self-relieving
- 3 Self-relieving

#### OUTLET RANGE

- I 0–250 psig
- J 0–500 psig
- W 0–750 psig
- K 0–1000 psig
- L 0–2000 psig
- N 0–4000 psig

## Maximum Temperature & Operating Inlet Pressures

| SEAT MATERIAL              | MAXIMUM TEMPERATURE | @ | MAXIMUM OPERATING INLET PRESSURE |
|----------------------------|---------------------|---|----------------------------------|
| PCTFE (formerly Kel-F® 81) | 175° F (80° C)      | @ | 4000 psig (27.58 MPa)            |
| Teflon®                    | 150° F (66° C)      | @ | 1000 psig (6.90 MPa)             |

## Outline and Mounting Dimensions

Weight = 4.4 lbs (2.0kg)

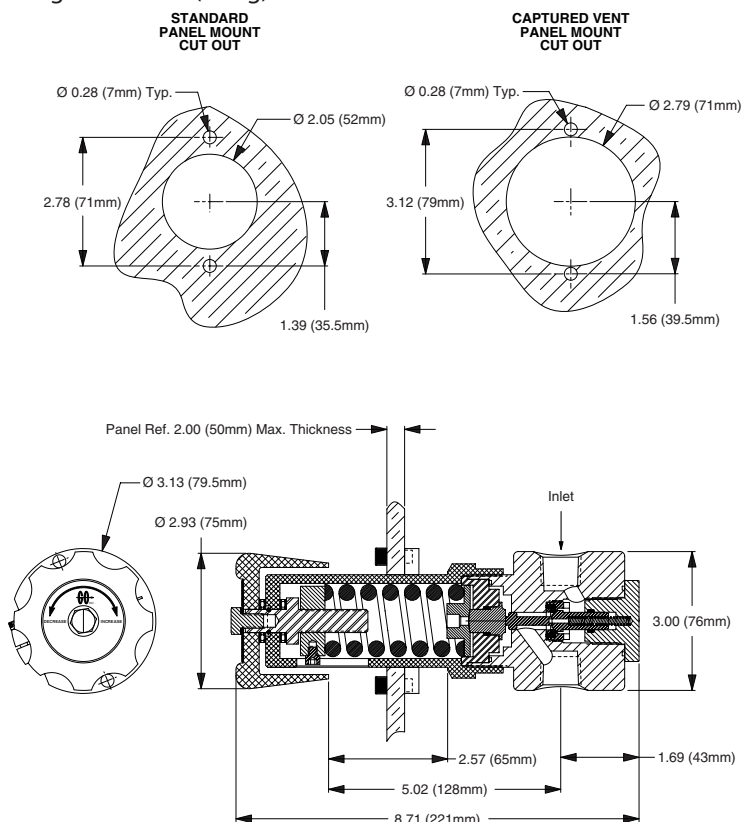

Kel-F® is a registered trademark of 3M Company.

Viton® is a registered trademark of DuPont Dow Elastomers.

Monel® is a registered trademark of Special Metals Corporation.

Teflon® is a registered trademark of the DuPont Company.