

GO REGULATOR

PR-5 Series

High Flow Adjustable Pressure Reducing Regulator



The PR-5 Series pressure regulator is designed for service at high flows with good sensitivity and regulation. While the design was originated for gas systems, this valve is perfectly suitable for liquid systems that are compatible with the materials of construction. The PR-5 also performs well with just a few liters per minute of flow.

This series is a variation of the time proven PR-1 Series which has been used for many applications in systems requiring stainless steel construction. The exact package size of the PR-1 has been retained making it convenient for the user to interchange these units if better control at high flow rates is required.

Features & Specifications

- High flow capability in compact size
- Minimum droop with large flow increases
- Bubble-tight shutoff
- Stainless steel cap & adjusting screw provided with stainless steel unit
- Materials of construction: stainless steel, brass, Teflon®, Viton®, Kalrez®, Buna N, or EPR
- 20 micron inlet filter
- Operating temperatures up to +400° F (+204° C)
- Ideal for line regulator applications
- Teflon®/Viton® diaphragm standard up to 50 psig
- Inlet pressure 300 psig
- Adjustable outlet ranges 0–10, 0–25, 0–50, 0–100, & 0–250 psig
- Cv flow coefficient 0.20

Options

- Panel mount (requires 1 $\frac{3}{8}$ " mounting hole)
- Extra ports
- Special welded connections
- Pressure gauges
- Captured vent

GO Regulator

405 Centura Court • PO Box 4866 • Spartanburg, SC 29303
Phone (864) 574-7966 Fax (864) 574-5608
www.goreg.com • sales@goreg.com

pressure regulators

PR-5 Series

How to Order

PR5 -

BODY MATERIAL

- 1 316L stainless steel
- 2 Brass
- 4 Monel®
- 6 Hastelloy® C

PORT CONFIGURATION

- A Standard

For more port configurations, see page 35.

PROCESS PORT TYPES

(GAUGE PORT TYPES, IF SPECIFIED)

- 0 1/8" FNPT (1/8" FNPT gauge ports)
- 1 1/4" FNPT (1/4" FNPT gauge ports)
- 2 1/4" tube stub, 2" long (1/4" FNTP gauge ports)
- 3 1/4" sch 80 pipe stub, 4" long (1/4" FNPT gauge ports)
- 4 3/8" FNPT (1/4" FNPT gauge ports)
- K 1/4" sch 40 pipe stub, 4" long (1/4" FNPT gauge ports)

SURFACE FINISH OF DIAPHRAGM CAVITY

- 1 < 25 Ra, standard
- 4 Filled

SEAT MATERIAL

- D Viton® (standard)
- E EPR
- J Buna N
- K Kalrez®

FLOW COEFFICIENT (Cv)

- 5 0.2

OUTLET RANGE

- C 0-10 psig
- D 0-25 psig
- E 0-50 psig
- G 0-100 psig
- I 0-250 psig

OPTIONAL CAP FINISH

- 1 Chrome-plated
- 2 Electroless nickel-plated

CAP ASSEMBLY

- 1 Standard
- 4 Panel mount
- 5 Captured vent, aluminum
- 8 Tamper-proof
- 9 Fine adjust, 1/2" panel mount, stainless steel
- A Captured vent, tamper-proof, aluminum
- H 1/4" NPT dome-loaded

DIAPHRAGM FACING/BACKING MATERIAL

- 1 Teflon®/stainless steel
- 2 Teflon®/Viton®
- 3 Teflon®/EPR
- 4 Teflon®/Buna N
- 6 Tefzel® ring/stainless steel
- 7 Viton®/stainless steel
- 8 Teflon®/Inconel®
- 0 Teflon®/Hastelloy® C
- C EPR/stainless steel
- D EPR/Viton®
- I Viton®/Inconel®

DIAPHRAGM TYPE

- 1 Standard diaphragm
- 3 Self-relieving
- 4 Vacuum assist spring, standard diaphragm
- 7 Liquid service

Maximum Temperature & Operating Inlet Pressures

SEAT MATERIAL	MAXIMUM TEMPERATURE*	@	MAXIMUM OPERATING INLET PRESSURE
Viton®	400° F (204° C)	@	300 psig (2.07 MPa)
EPR	150° F (66° C)	@	300 psig (2.07 MPa)
Buna N	150° F (66° C)	@	300 psig (2.07 MPa)
Kalrez®	400° F (204° C)	@	300 psig (2.07 MPa)

* Temperatures in excess of 175° F (80° C) require a metal knob or the tamper-proof option.

Outline and Mounting Dimensions

Weight = 1.9 lbs (0.86 kg)

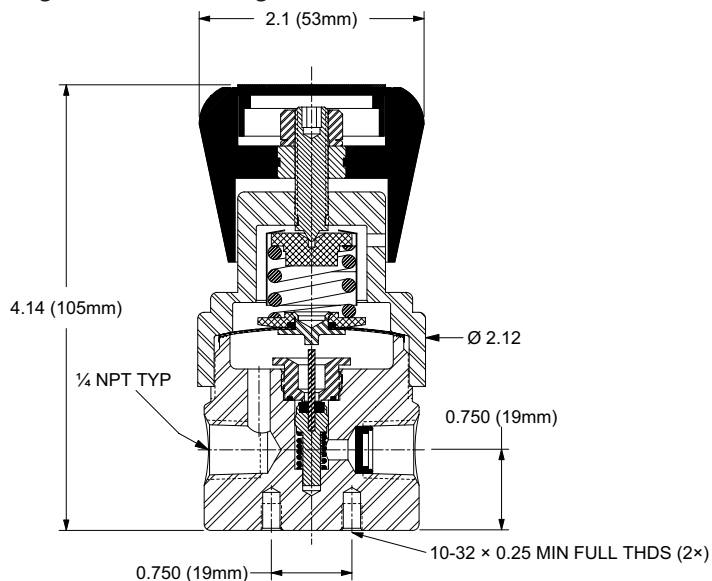

Monel® is a registered trademark of Special Metals Corporation.
 Teflon® is a registered trademark of the DuPont Company.
 Kalrez® and Viton® are registered trademarks of DuPont Dow Elastomers.
 Hastelloy® is a registered trademark of Haynes International, Inc.