

GO REGULATOR

PR-1 Series

Adjustable Pressure Reducing Regulator



The PR-1 Series is a versatile pressure reducing regulator designed to fulfill a wide range of needs in instrumentation sample systems and other applications such as semiconductor processing gases. Many features of the PR-1 make it ideal for a wide range of applications controlling pressures at low to moderate flows in gas or liquid service. 316L body material is used to facilitate welded connections. Stainless steel caps and adjusting screws prevent atmospheric corrosion and maintain appearance. Enhanced internal body surface finish of better than 25 Ra plus electropolishing allows easier cleaning and potentially less particle contamination in the flow stream.

Five different seat materials, three alternate orifice sizes and seven pressure control ranges with stainless diaphragms offer the user a wide spectrum of capabilities for pressure control with inlet pressures up to 6000 psig and standard operating temperatures up to 500° F (260° C).

Features & Specifications

- Gas or liquid service
- 316L stainless steel, Inconel®, Teflon®, and Tefzel® (or optional main seat material choice) only in flow stream
- Electropolished 316L body with better than 25 Ra diaphragm cavity surface finish
- Stainless steel cap with SS adjusting screw
- Inlet pressures of up to 6000 psi
- Adjustable outlet pressure ranges of 0–10, 0–25, 0–50, 0–100, 0–250, 0–500 and 0–750 psig
- Operating temperatures of –40° F up to +500° F (–40° C up to +260° C)
- 20 micron filters
- Bubble-tight shutoff under most conditions
- Cv flow coefficients 0.025, 0.06, 0.20, and 0.50 (0.06 standard)

Options

- Wetted materials of construction: Monel®, Hastelloy®, and titanium
- Diaphragm attached poppet
- Special fittings
- Diaphragm assist spring for vacuum purging
- Panel mount (1 $\frac{3}{8}$ " mounting hole)
- Relief valves
- Special diaphragm assembly for water service
- SS inlet pressure gauges
- SS outlet pressure gauges
- Base-mounting brackets
- Captured vent
- Self-relieving

GO Regulator

405 Centura Court • PO Box 4866 • Spartanburg, SC 29303
Phone (864) 574-7966 Fax (864) 574-5608
www.goreg.com • sales@goreg.com

pressure regulators

PR-1 Series

How to Order

PR1 -

BODY MATERIAL

- 1 316L stainless steel
- 4 Monel®
- 6 Hastelloy® C

PORT CONFIGURATION

- A Standard
- For more port configurations see page 35.

PROCESS PORT TYPES (GAUGE PORT TYPES, IF SPECIFIED)

- 0 1/8" FNPT (1/8" FNPT gauge ports)
- 1 1/4" FNPT (1/4" FNPT gauge ports), standard
- 3 1/4" sch 80 pipe stub, 4" long (1/4" FNPT gauge ports)
- 4 3/8" FNPT (1/4" FNPT gauge ports)
- H 1/4" sch 160 pipe stub, 4" long (1/4" FNPT gauge ports)
- K 1/4" sch 40 pipe stub, 4" long (1/4" FNPT gauge ports)

SURFACE FINISH OF DIAPHRAGM CAVITY

- 1 < 25 Ra, standard

SEAT MATERIAL

- A Tefzel®
- B CF Teflon®
- C Polyimide, high temperature service (metal knob standard)
- H PCTFE (formerly Kel-F® 81)
- I High density Teflon®
- Q PEEK™

CAP ASSEMBLY

- 1 Standard, stainless steel
- 4 Panel mount, stainless steel
- 5 Captured vent, aluminum
- 8 Tamper-proof, stainless steel
- C Metal knob, panel mount
- G Metal knob
- H 1/4" NPT dome-loaded, stainless steel
- J Captured vent, panel mount, stainless steel

DIAPHRAGM FACING/BACKING MATERIAL

- 1 Teflon®/stainless steel
- 6 Tefzel® ring/stainless steel
- 8 Teflon®/Inconel®
- 0 Teflon®/Hastelloy® C
- J Tefzel® ring/Inconel®

DIAPHRAGM TYPE

- 1 Standard diaphragm
- 2 Diaphragm attached poppet (DAP)
- 3 Self-relieving
- 4 Vacuum assist spring, standard diaphragm

OUTLET RANGE

- C 0-10 psig
- D 0-25 psig
- E 0-50 psig
- G 0-100 psig
- I 0-250 psig
- J 0-500 psig
- W 0-750 psig

FLOW COEFFICIENT (Cv)

- 3 0.06, standard
- 5 0.2
- C 0.025
- H 0.5

Maximum Temperature & Operating Inlet Pressures

| SEAT MATERIAL | MAXIMUM TEMPERATURE* | @ | MAXIMUM OPERATING INLET PRESSURE |
|----------------------------|----------------------|---|----------------------------------|
| Tefzel® | 150° F (66° C) | @ | 3600 psig (24.82 MPa) |
| High density Teflon® | 150° F (66° C) | @ | 3600 psig (24.82 MPa) |
| PCTFE (formerly Kel-F® 81) | 175° F (80° C) | @ | 6000 psig (41.37 MPa) |
| Polyimide | 500° F (260° C) | @ | 3600 psig (24.82 MPa) |
| Polyimide | 175° F (80° C) | @ | 6000 psig (41.37 MPa) |
| PEEK™ | 500° F (260° C) | @ | 3600 psig (24.82 MPa) |
| PEEK™ | 175° F (80° C) | @ | 6000 psig (41.37 MPa) |

* Temperatures in excess of 175° F (80° C) require a metal knob or the tamper-proof option.

Outline and Mounting Dimensions

Panel mount option requires 1.390 (35.3mm) minimum diameter panel cut out. 0.150 maximum panel thickness.

Weight = 1.9 lbs (0.86 kg)

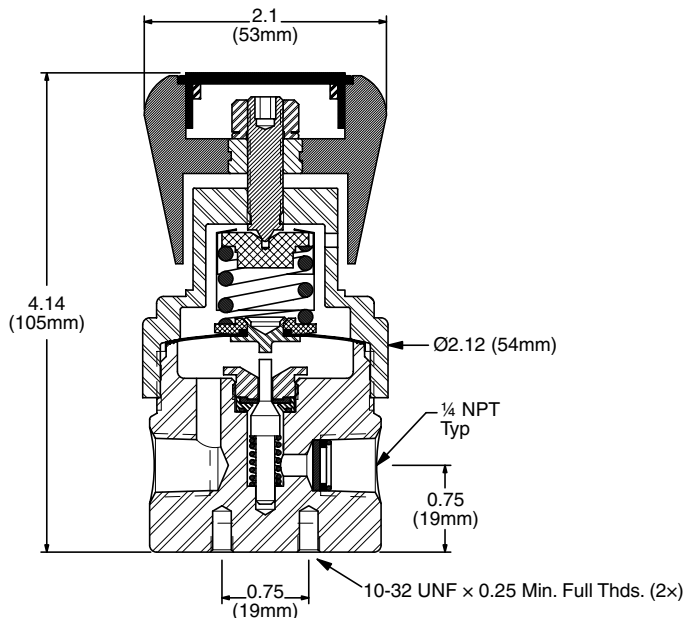

Inconel® and Monel® are registered trademarks of Special Metals Corporation.
 Teflon® and Tefzel® are registered trademarks of the DuPont Company.
 Hastelloy® is a registered trademark of Haynes International, Inc.
 Kel-F® is a registered trademark of 3M Company.
 PEEK™ is a trademark of Victrex PLC.