



GO REGULATOR

HPR-2XW Series

Electrically Heated Pressure Regulators

The HPR-2XW Series heated pressure regulator is designed to supply heat to samples entering instrumentation systems. It can be used to preheat liquids, to prevent condensation of gases or to vaporize liquids prior to gas analysis.

The modular design of the HPR-2XW consists of heat exchanger and pressure control sections. The pressure control section is patterned after the time proven design of the PR-1 pressure reducing regulator and provides the same excellent outlet pressure stability. The heat exchanger section is made up of a body and heat exchange element. The heat exchange element uses GO Regulator's unique spiral wrapped screen as the heat exchanger surface. This screen has up to 100 square inches of heat transfer area and careful design forces all sample flow to pass through the element.

Completing this modular design is the incorporation of a removable heat exchanger unit. This allows the user to remove and clean, or replace the exchanger. This is especially useful when heating dirty liquids or liquids that polymerize and clog the heat exchange screen.

The HPR-2 Series of vaporizing pressure reducing regulators enjoy both CSA and KEMA (Cenelec) approvals. The electrical components of this unit are securely housed in a Class A,B,C,D conduit assuring that there is always an adequate flame path between the environment and the controller. Safety considerations can be further enhanced by using the optional TCO (Thermal Cut Out) heater cartridge and proportional controller. These features enable the unit to boast a T3 rating with 150 watts of power.

Features & Specifications

- 316L stainless steel construction
- Optional Hastelloy C & Monel
- Electropolished body with better than 25 Ra finish in diaphragm cavity
- Operating temperatures up to 380° F (193° C)
- Bubble tight shutoff
- Outlet pressures 0–10, 0–25, 0–50, 0–100, 0–250 and 0–500 psig
- Modular pressure control and heat exchanger assemblies for easy maintenance
- Unique spiral wrapped heat exchange element provides up to 100 square inches of heat transfer area
- Available in 110VAC or 240VAC
- Heating capacity ranges are 40, 50, 100 and 150 watts
- Optional TCO heating cartridge and proportional controller
- CSA certification # LR-82566-5
- KEMA certification # Ex-96.D.1862
- C_v flow coefficients of 0.06, 0.025, 0.2

405 Centura Court
PO Box 4866
Spartanburg, SC 29303
tel 864.574.7966
fax 864.587.5608
www.goreg.com
sales@goreg.com

HPR-2XW Electrically Heated Regulators

How to Order

See page 3 for standard configurations. Consult factory for additional configurations. Port locations, see pages 4 and 5.

Maximum Temperature & Operating Inlet Pressures

HPR-2XW Electric 2 Piece Assembly

Seal Material	Maximum Temperature	@	Maximum Operating Inlet Pressure
Tefzel®	Up to 175° F (80° C)	@	3600 psig (24.82 MPa)
	176° F to 300° F (80° C to 148° C)	@	1000 psig (6.90 MPa)
	301° F to 380° F (148° C to 193° C)	@	400 psig (2.76 MPa)
High Density Teflon®	Up to 175° F (80° C)	@	3600 psig (24.82 MPa)
	176° F to 300° F (80° C to 148° C)	@	1000 psig (6.90 MPa)
	301° F to 380° F (148° C to 193° C)	@	400 psig (2.76 MPa)
PCTFE (formerly Kel-F81)	Up to 380° F (193° C)	@	3600 psig (24.82 MPa)
Polyimide	Up to 380° F (193° C)	@	3600 psig (24.82 MPa)
PEEK	Up to 380° F (193° C)	@	3600 psig (24.82 MPa)

HPR-2XW Electric 1 Piece Assembly

Seal Material	Maximum Temperature	@	Maximum Operating Inlet Pressure
Tefzel®	Up to 175° F (80° C)	@	3600 psig (24.82 MPa)
	176° F to 300° F (80° C to 148° C)	@	1000 psig (6.90 MPa)
	301° F to 380° F (148° C to 193° C)	@	400 psig (2.76 MPa)
High Density Teflon®	Up to 175° F (80° C)	@	3600 psig (24.82 MPa)
	176° F to 300° F (80° C to 148° C)	@	1000 psig (6.90 MPa)
	301° F to 380° F (148° C to 193° C)	@	400 psig (2.76 MPa)
PCTFE (formerly Kel-F81)	Up to 380° F (193° C)	@	3600 psig (24.82 MPa)
Polyimide	Up to 380° F (193° C)	@	6000 psig (41.37 MPa)
PEEK	Up to 380° F (193° C)	@	6000 psig (41.37 MPa)

Tefzel® and Teflon® are registered trademarks of Dupont.

Outline and Mounting Dimensions

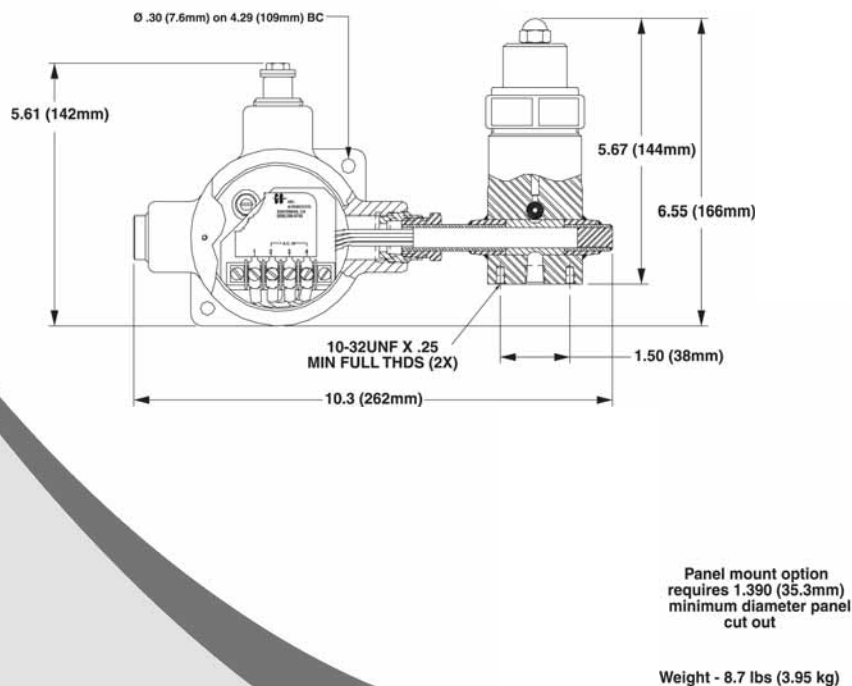

HPR-2XW Electrically Heated Vaporizing Regulators

Material of Body	
1	SS 316L
4	Monel
Port Configuration (page 4)	
STANDARD BODY "Z" (ONE INLET PORT AND ONE OUTLET PORT)	
Z	
Temperature Range/Heating Type	
1	55° F - 85° F
2	75° F - 175° F
3	130° F - 300° F
4	260° F - 380° F
Heater Wattage	
1	40W
2	50W
3	100W
4	150W
Seat Material	
A	Tefzel
B	CF Teflon
C	Polyimide
H	PCTFE (formerly Kel-F 81)
Q	PEEK
Flow Coefficient (Cv)	
3	0.06
Output Range	
C	0 - 10 Psig
D	0 - 25 Psig
E	0 - 50 Psig
G	0 - 100 Psig
I	0 - 250 Psig
J	0 - 500 Psig
Heater Block Type	
6	110 VAC HPR-2XW
7	240 VAC HPR-2XW
0	Proportional 110 VAC HPR-2XW
A	Proportional 240 VAC HPR-2XW
Heater Block Porting (page 36)	
1	Standard Block
2	Extra Outlet Block
Cap Assembly	
1	Tamper Proof, Standard, S.S.
Other Options (Can be left blank)	
1	TCO Thermistor
5	5600 Psig inlet w/ TCO Thermistor (1pc assy.)
7	6000 Psig inlet w/ Standard Thermistor (1pc assy.)

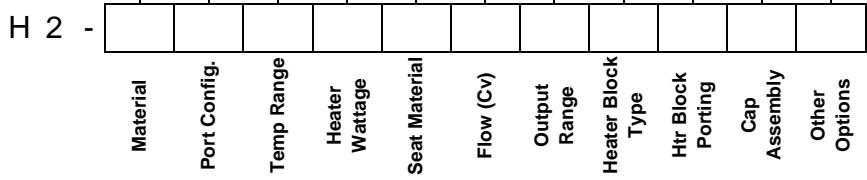

REGULATOR BODY PORTING CONFIGURATIONS FOR HPR-2 (STEAM & ELECTRIC) & HPR-2XW (STEAM & ELECTRIC)

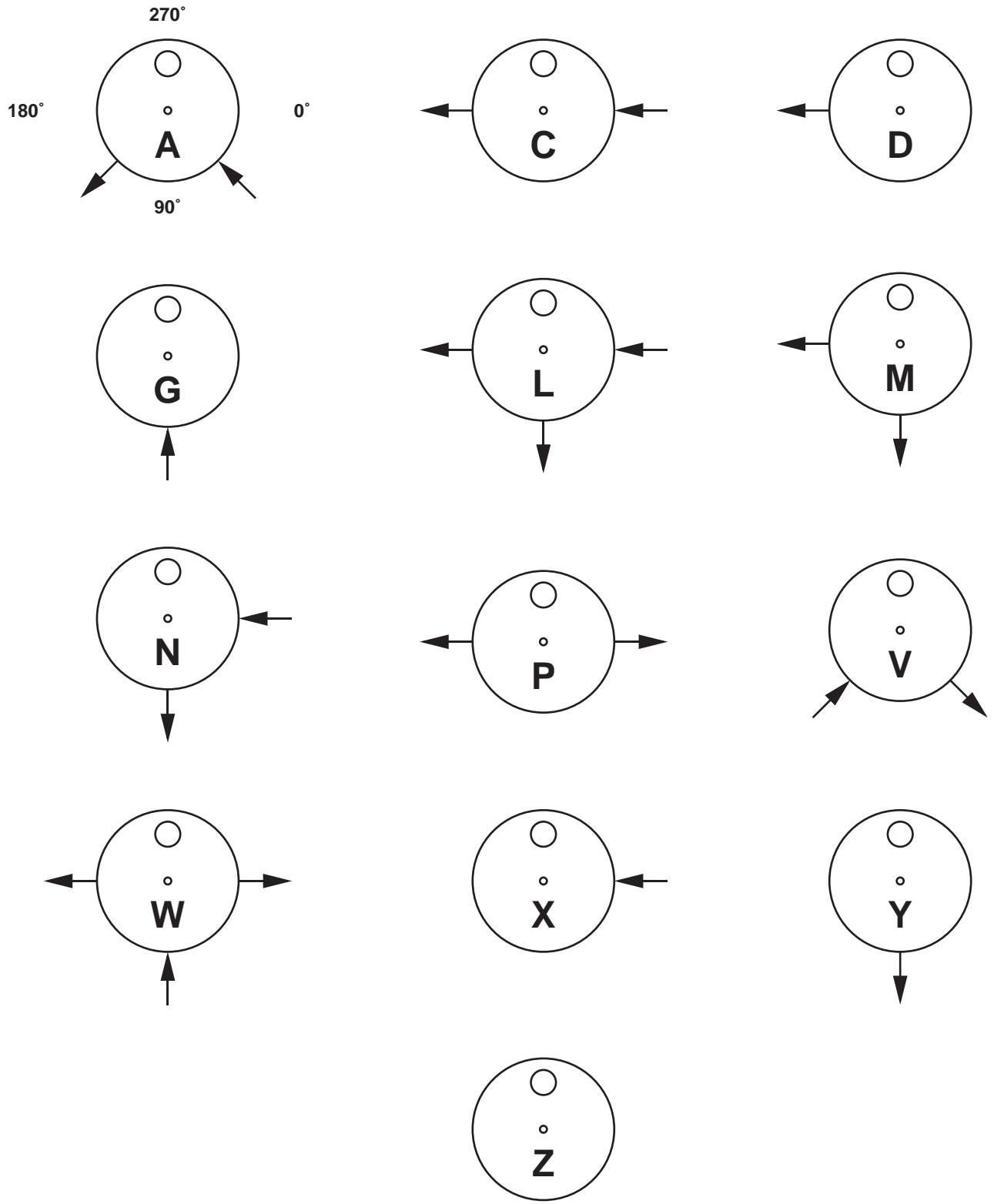

LOCATION OF PORTS FROM TOP VIEW
ARROW POINTING TOWARD BODY IS INLET
ARROW POINTING AWAY FROM BODY IS OUTLET

HEATER BLOCK CONFIGURATIONS FOR HPR-2 (STEAM & ELECTRIC) & HPR-2XW (STEAM & ELECTRIC)

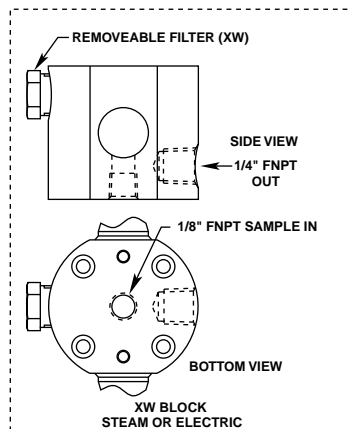
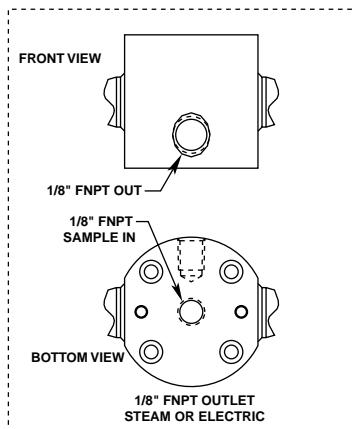
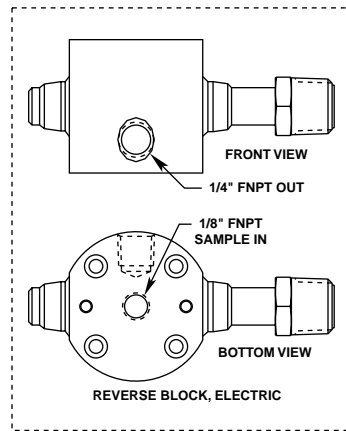
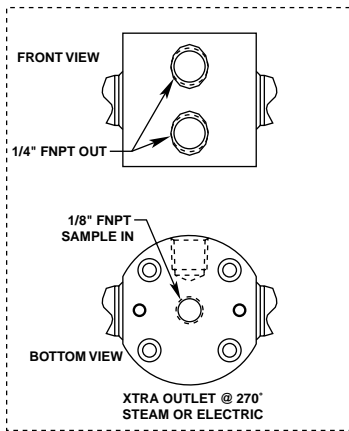
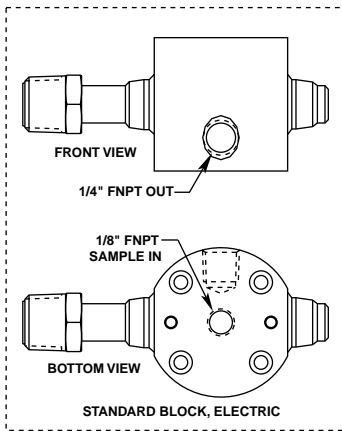
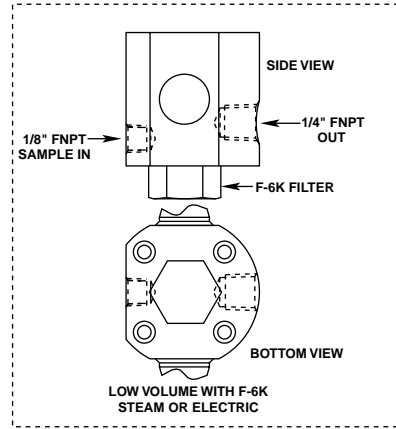
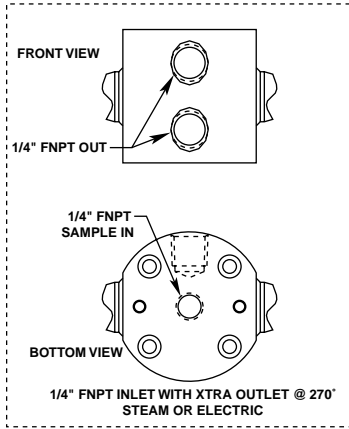
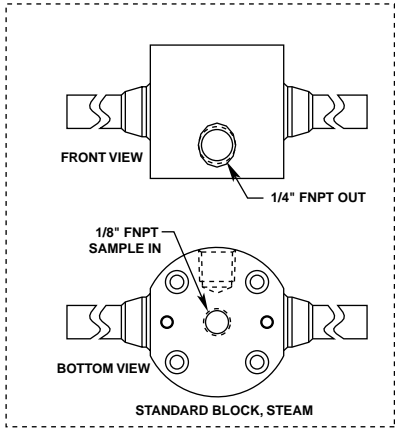

HEATER BLOCK CONFIGURATIONS FOR HPR-2 (STEAM & ELECTRIC) & HPR-2XW (STEAM & ELECTRIC) (CONTINUED)

