



# **GO** REGULATOR

## **Cyclone Single and Dual Element Type Filter**

The Cyclone filter's unique design provides an unsurpassed combination of rapid response, minimum dead volume and high filtration efficiency. Using the proven bypass design, a large sample flow is brought to the filter so the sample transport lag time is minimized. Only that portion of the sample needed for the process analyzer passes through the filter element. In this manner, low filtration rates and rapid responses are achieved. Careful flow design causes the unfiltered portion of the sample to sweep the filter element's surface to greatly extend the element's life. With the simple installation of a pipe plug in the bypass port, the Cyclone bypass filter can be converted to a line filter. All Cyclone filters have back-up screens to support the filter element and can be supplied with an optional stainless steel mounting bracket. Cyclone filters are available in two standard materials, 316 stainless steel and Monel. On special order, filters can be supplied in other machinable materials.

### **Features & Specifications**

- Material of construction is 316L stainless steel
- Available in Monel, Hastelloy, or Titanium
- Filter element material is a Teflon® membrane
- O-ring seal material is available in either Teflon® or Viton®
- Available filter element porosities are 0.2, 1.0, 5.0 and 10 microns
- Minimum flow rate on filtered side is 100cc/min of vapor or 50ml/in of liquid
- Minimum flow rate on bypass side should be about 10 times the sample flow rate

405 Centura Court  
PO Box 4866  
Spartanburg, SC 29303  
tel 864.574.7966  
fax 864.587.5608  
www.goreg.com  
sales@goreg.com

# Cyclone Single and Dual Element Type Filter

How to Order—See page 3 for ordering matrix.  
**Specifications**

	Single Element	Double Element
Body Material	316 SS, Monel, (Hastelloy C), (Titanium)	
Filter Element Material	Teflon® Membrane	
O-ring Seal Material	Teflon® or Viton®	
Filter Element Pore Sizes	0.2, 1.0, 5.0 & 10	
Effective Filter Area	11.3 sq. cm., 1.78 sq. in.	22.6 sq. cm., 3.56 sq. in.
Internal Volume		
Filtered side	6.8 cu cm, 0.45 cu. in.	13.6 cu cm, 0.9 cu. in.
Bypass side	25.3 cu cm, 1.56 cu. in.	30.0 cu cm, 1.8 cu. in.
Pressure & Temperature Ratings	3600 PSIG @ 70° F (20° C) 1500 PSIG @ 175° F (80° C)	
Recommended Flow Rates		
Filtered side	Minimum flow of 100 cc/min vapor and 50 ml/min liquid to minimize transport lag	
Bypass side	Flow should be about 10 times sample flow	
Connections	All connections are 1/8" or 1/4" Female NPT	
Weight	2.5 lbs (1.13kg)	3.2 lbs (1.45kg)

## Maximum Temperature & Operating Inlet Pressures

Seat Material	Maximum Temperature	@	Maximum Operating Inlet Pressure
Viton®	70° F (20° C)	@	3600 psiG (24.82 MPa)
	175° F (80° C)	@	1500 psiG (10.35 MPa)
Teflon®	70° F (20° C)	@	3600 psiG (24.82 MPa)
	150° F (66° C)	@	1500 psiG (10.35 MPa)

\* Temperature in excess of 175° F (80° C) require the use of a metal knob or the tamper proof option.  
 Tefzel® and Teflon® are registered trademarks of Dupont.

### SINGLE ELEMENT

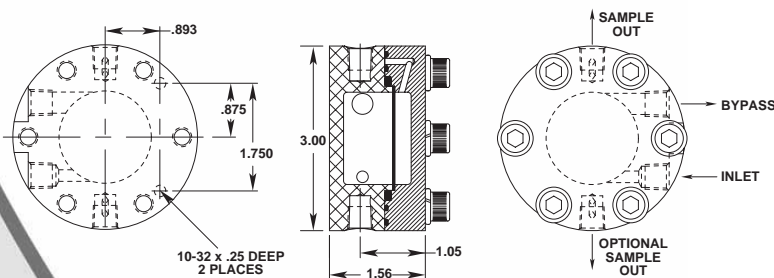

### DOUBLE ELEMENT

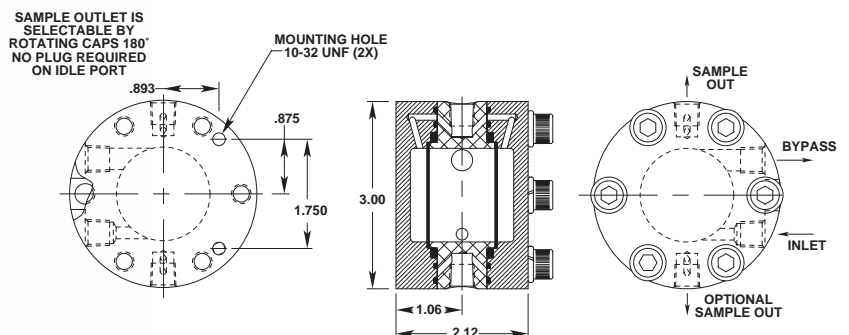

**BODY MATERIAL**

1	316L Stainless Steel
4	Monel
6	Hastelloy C

**PORT TYPE**

0	1/8" FNPT
1	1/4" FNPT

**FILTER TYPE**

1	Single Element
2	Dual Element

**O-RING MATERIAL**

D	Viton®
I	Teflon®

**MICRON RATING**

1	0.20 Micron
3	1.0 Micron
5	5.0 Micron
9	10-15 Micron

**FILTER MOUNTING BRACKETT**

1	Include Mounting Brackett
0	Omit Mounting Brackett

CF --



Body Material

Port Type

Filter Type

O-ring Material

Micron Rating

Mount Brackett