



GO REGULATOR

CYL-21 Series Corrosion Resistant Single Stage Cylinder Regulator

The CYL-21 Series is a compact cylinder regulator based on the time proven design of the PR-1 Series single stage stainless steel line regulator and is suitable for most corrosive gas cylinder applications. While normally used for low and moderate flow service, optional high flow orifices are available.

The standard unit is equipped with CGA connector, integral inlet filter, inlet and outlet pressure gauges and may be ordered with extra inlet or outlet ports for inlet purging, outlet relief valves or other accessory items. When used in service with toxic or explosive gases, we recommend the installation of a captured vent option. This option is a true captured vent cap and not merely a standard cap with a vent port. It comes complete with a CGA fitting and 2" diameter gauges.

Features & Specifications

- 316L stainless steel construction (standard), Monel optional
- Inlet pressures up to 6000 psig
- Electropolished body with better than 25 Ra finish in diaphragm cavity
- 20 micron inlet filter
- Bubble tight shutoff
- CGA inlet fitting
- 2" diameter 316 stainless steel gauges
- Outlet pressure ranges 0–10, 0–25, 0–50, 0–100, 0–250 and 0–500 psig
- Optional C_v flow coefficients 0.025, 0.06, 0.20, 0.50

405 Centura Court
PO Box 4866
Spartanburg, SC 29303
tel 864.574.7966
fax 864.587.5608
www.goreg.com
sales@goreg.com

CYL-21 Series

Corrosion Resistant Single Stage Cylinder Regulator

How to Order

See page 3 for standard configurations. For additional configurations, consult the factory.
See page 4 for port locations.

Maximum Temperature & Operating Inlet Pressures

Seat Material	Maximum Temperature*	@	Maximum Operating Inlet Pressure
Tefzel®	150° F (66° C)	@	3600 psig (24.82 MPa)
High Density Teflon®	150° F (66° C)	@	3600 psig (24.82 MPa)
PCTFE (formerly Kel-F81)	175° F (80° C)	@	6000 psig (41.37 MPa)
Polyimide	500° F (260° C)	@	3600 psig (24.82 MPa)
Polyimide	175° F (80° C)	@	6000 psig (41.37 MPa)
PEEK	500° F (260° C)	@	3600 psig (24.82 MPa)
PEEK	175° F (80° C)	@	6000 psig (41.37 MPa)

* Temperatures in excess of 175° F (80° C) require the use of a metal knob or the tamper proof option.
Tefzel® and Teflon® are registered trademarks of Dupont.

Outline and Mounting Dimensions

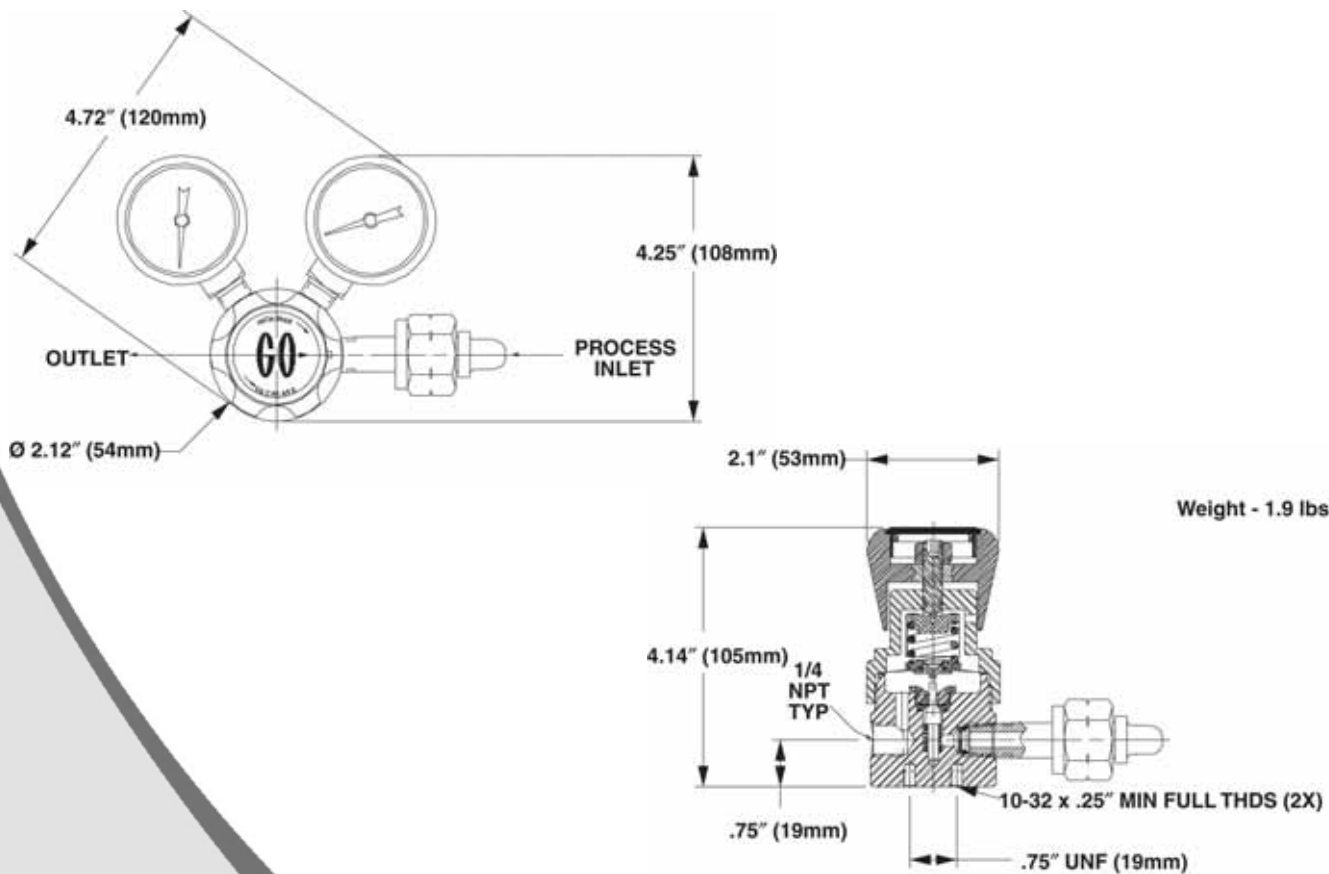

For flow curve charts, go to www.goreg.com/catalog/pr/cyl/cyl21/cyl21_flow.htm.

CYL-21 Series - Pressure Reducing Regulators

1		Material of Body									
4		SS 316L									
4		Monel									
F		Port Configuration (see page 4) STANDARD BODY "F" (TWO INLET PORTS AND TWO OUTLET PORTS)									
1		Process port types (gauge port type, if specified)									
2		1/4" FNPT (1/4" FNPT Gauge ports)									
3		1/4" Tube (1/4" Tube Gauge ports)									
3		1/4" Sch 80 Pipe (1/4" FNPT Gauge ports)									
4		3/8" FNPT (1/4" FNPT Gauge ports)									
6		1/2" Tube (1/4" Tube Gauge ports)									
K		1/4" Sch 40 Pipe (1/4" FNPT Gauge ports)									
1		Diaphragm Type									
2		Standard Diaphragm									
3		Diaphragm Attached Poppet									
4		Self Relieving									
5		Vacuum Assist Spring, Standard Diaphragm									
8		Vacuum Assist Spring, Diaphragm Attached Poppet									
8		Tefzel Ring / SS									
A		Seat Material									
B		Tefzel									
C		CF Teflon									
H		Polyimide									
I		PCTFE (formerly Kel-F 81)									
Q		High Density Teflon									
Q		PEEK									
3		Flow Coefficient (Cv)									
5		0.06									
C		0.2									
H		0.025									
H		0.5									
C		Output Range									
D		0 - 10 Psig									
E		0 - 25 Psig									
G		0 - 50 Psig									
I		0 - 100 Psig									
J		0 - 250 Psig									
J		0 - 500 Psig									
1		Cap Assembly									
4		Standard									
4		Panel Mount									
		CGA Fitting									
		Use 0 in all boxes to omit CGA.									
		Use "CUS" in boxes for customer supplied CGA.									
		Gauges									
		1 Include Gauges									
		2 Omit Gauges									
		3 Customer Supplied									

C 1 -

Material	Port Config.	Port Style	Diaphragm Type	Seat Material	Flow Coefficient (Cv)	Output Range	Cap Assembly	C	G	A	Gauges
----------	--------------	------------	----------------	---------------	-----------------------	--------------	--------------	---	---	---	--------

PORT LOCATIONS (CYLINDER REGULATORS)

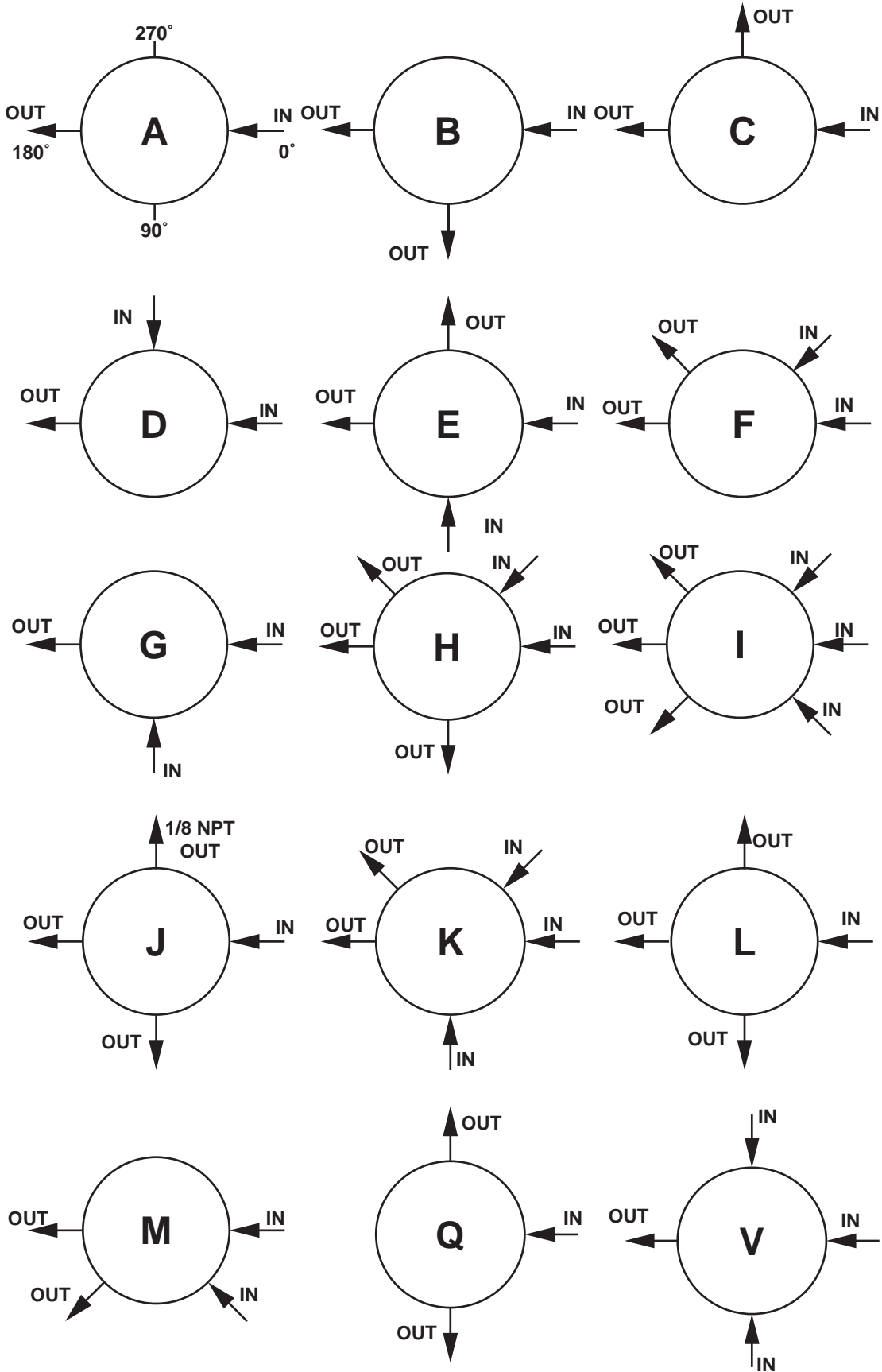

LOCATION OF PORTS FROM TOP VIEW