



GO REGULATOR

Cylinder Vaporizer Steam Heated Two Stage Pressure Regulators

The Cylinder Vaporizer Series Heated Pressure Regulator is designed to supply heat to samples entering instrumentation systems. It can be used to preheat liquids, to prevent condensation of gases or to vaporize liquids prior to gas analysis.

The design of the Cylinder Vaporizer consists of heat exchanger and pressure control sections. The pressure control section is patterned after the time proven design of the CYL-20 two-stage pressure reducing regulator and provides the same excellent outlet pressure stability with varying inlet pressures. The heat exchange element uses GO Regulator's unique spiral wrapped screen as the heat exchange surface. This screen has up to 100 square inches of heat transfer area and careful design forces all sample flow to pass through the element.

Features & Specifications

- 316L stainless steel construction
- Optional Hastelloy C and Monel
- Electropolished body with better than 25 Ra finish in diaphragm cavity
- Steam temperatures up to 550° F (285° C)
- Bubble tight shutoff
- Outlet pressure 0–10, 0–25, 0–50, 0–100, 0–250 and 0–500 psig
- Unique spiral wrapped heat exchange element provides up to 100 square inches of heat transfer area
- C_v flow coefficients of 0.06, 0.025, 0.2

405 Centura Court
PO Box 4866
Spartanburg, SC 29303
tel 864.574.7966
fax 864.587.5608
www.goreg.com
sales@goreg.com

Cylinder Vaporizer Steam Heated Two Stage Pressure Regulators

How to Order

See page 3 for standard configurations. Consult factory for additional configurations.

Maximum Temperature & Operating Inlet Pressures

Seat Material	Maximum Temperature	@	Maximum Operating Inlet Pressure
Tefzel®	Up to 175°F (80° C)	@	3600 psig (24.82 MPa)
	176° F to 300° F (80° C to 148° C)	@	1000 psig (6.90 MPa)
	301° F to 380° F (148° C to 193° C)	@	400 psig (2.76 MPa)
High Density Teflon®	Up to 175° F (80° C)	@	3600 psig (24.82 MPa)
	176° F to 300° F (80° C to 148° C)	@	1000 psig (6.90 MPa)
	301° F to 380° F (148° C to 193° C)	@	400 psig (2.76 MPa)
PCTFE (formerly Kel-F81)	Up to 380° F (193° C)	@	3600 psig (24.82 MPa)
Polyimide	Up to 380° F (193° C)	@	6000 psig (41.37 MPa)
PEEK	Up to 380° F (193° C)	@	6000 psig (41.37 MPa)

Tefzel® and Teflon® are registered trademarks of Dupont.

Outline and Mounting Dimensions

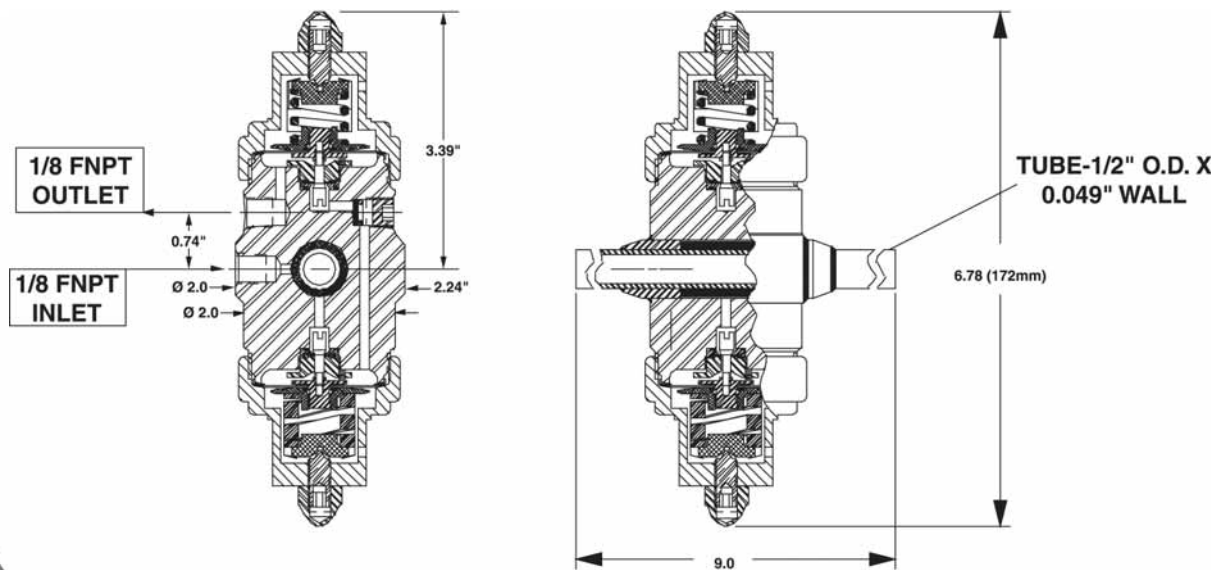

CV Two Stage Steam Heated Vaporizing Regulator

1		SS 316L		Material of Body	
4		Monel			
A		Port Configuration			
		STANDARD BODY "A" (ONE INLET PORT AND ONE OUTLET PORT)			
A		Seat Material (1st Stage)			
B		Tefzel			
C		CF Teflon			
H		Polyimide			
Q		PCTFE (formerly Kel-F 81)			
3		PEEK			
3		0.06			
		Flow Coefficient (Cv) (1st Stage)			
1		Cap Assembly (1st Stage)			
4		Tamper Proof, Standard, S.S.			
		Tamper Proof, Panel Mount, S.S.			
A		Seat Material (2nd Stage)			
B		Tefzel			
C		CF Teflon			
H		Polyimide			
Q		PCTFE (formerly Kel-F 81)			
3		PEEK			
3		0.06			
		Flow Coefficient (Cv) (2nd Stage)			
C		Output Range (2nd Stage)			
D		0 - 10 Psig			
E		0 - 25 Psig			
G		0 - 50 Psig			
I		0 - 100 Psig			
J		0 - 250 Psig			
		0 - 500 Psig			
1		Cap Assembly (2nd Stage)			
4		Tamper Proof, Standard, S.S.			
		Tamper Proof, Panel Mount, S.S.			
5		Temperature Range			
		Steam			
5		Heater Wattage			
		Steam			
5		Controller Type			
		Steam			
5		Thermistor Type			
		Steam			
5		Voltage			
		Steam			

