



# **GO** REGULATOR

## **CC2 Series Compact Two Stage Cylinder Pressure Regulator**

The CC2 Series compact two-stage precision pressure regulator is well suited for instrumentation applications requiring a precise and stable delivery pressure. This regulator was originally designed to meet the needs of the instrumentation industry, however it would also be very useful in many other applications that require a compact two stage pressure regulator to supply a precise delivery pressure with fluctuating supply pressures.

Another benefit of using the CC2 Series is that internally it shares some of its design features and options with the time proven CPR-1 Series pressure regulator. These features and options allow the customer to essentially tailor his regulator to accommodate virtually any application requiring low to moderate flow rates. Unit will also be offered with inlet/outlet pressure gauges, CGA connections and relief valves.

The CC2 Series Regulator is manufactured as a standard in aluminum. Please consult GO Regulator for any optional materials of construction that might be required for toxic or corrosive process gas applications.

### **Features & Specifications**

- Compact size
- Two stage regulation
- Stainless steel diaphragm
- Gas or liquid service
- Low internal volumes
- Maximum inlet pressure up to 3600 psig
- Outlet pressure ranges 0–10, 0–25, 0–50, 0–100, 0–250 and 0–500 psig
- $C_v$  flow coefficients 0.06, 0.025, 0.2
- Leak rate, bubble tight
- Operating temperatures -40° F (-40° C) to +175° F (+80° C)
- Inlet/outlet connections 1/8" FNPT, 1/4" tube

405 Centura Court  
PO Box 4866  
Spartanburg, SC 29303  
tel 864.574.7966  
fax 864.587.5608  
www.goreg.com  
sales@goreg.com

# CC2 Series

## Compact Two Stage Cylinder Pressure Regulator

### How to Order

See page 3 for standard configurations. For additional configurations, consult the factory.  
See page 4 for port locations.

### Maximum Temperature & Operating Inlet Pressures

Seat Material	Maximum Temperature	@	Maximum Operating Inlet Pressure
Tefzel®	150° F (66° C)	@	3600 psig (24.82 MPa)
PEEK	175° F (80° C)	@	3600 psig (24.82 MPa)
PCTFE (Formerly Kel-F-81)	175° F (80° C)	@	3600 psig (24.82 MPa)

Tefzel® is a registered trademark of Dupont.

### Outline and Mounting Dimensions

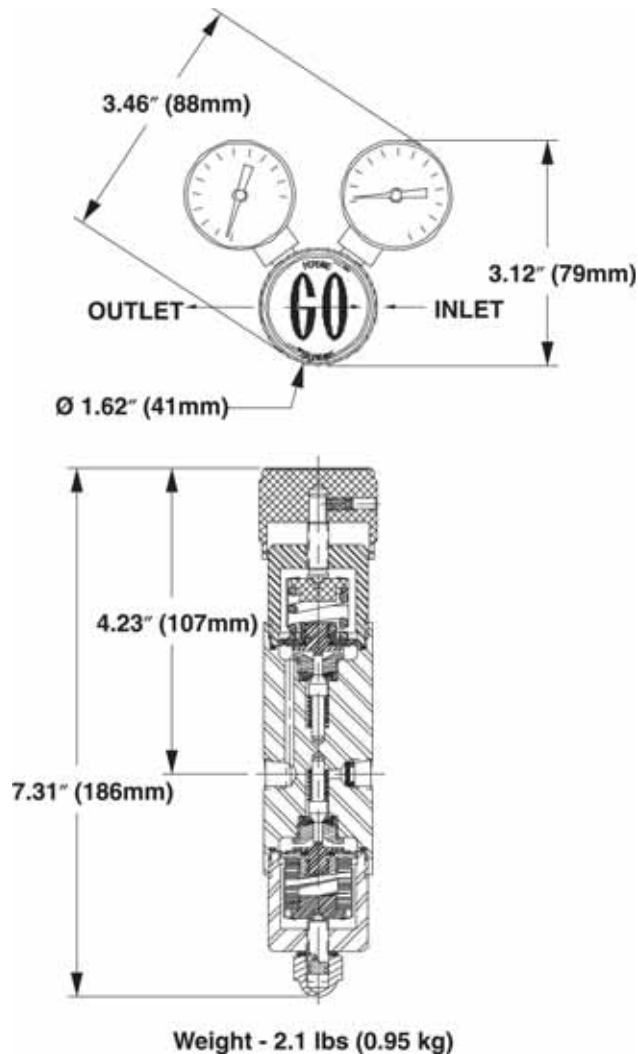

For flow curve charts, go to [www.goreg.com/catalog/pr/cyl/cc2/cc2\\_flow.htm](http://www.goreg.com/catalog/pr/cyl/cc2/cc2_flow.htm).

# CC-2 Series - Pressure Reducing Regulators

													<b>Material of Body</b>												
													1 SS 316L												
													2 Brass												
													3 Aluminum												
													<b>Port Configuration (see page 4)</b>												
													STANDARD BODY "F" (TWO INLET PORTS AND TWO OUTLET PORTS)												
													F												
													<b>Process port types (gauge port type, if specified)</b>												
													2 1/4" Tube (1/4" Tube Gauge ports)												
													0 1/8" FNPT (1/8" FNPT Gauge ports)												
													<b>Output Range</b>												
													C 0 - 10 Psig												
													D 0 - 25 Psig												
													E 0 - 50 Psig												
													G 0 - 100 Psig												
													I 0 - 250 Psig												
													J 0 - 500 Psig												
													<b>Diaphragm Type 1st Stage</b>												
													1 Standard												
													<b>Diaphragm Type 2nd Stage</b>												
													1 Standard												
													<b>Cap Assembly 1st Stage</b>												
													1 Tamper Proof												
													4 Tamper Proof, Panel Mount												
													5 Tamper Proof, Captured Vent												
													<b>Cap Assembly 2nd Stage</b>												
													1 Standard, Aluminum												
													4 Panel Mount, Aluminum												
													5 Captured Vent, Aluminum												
													7 Captured Vent, S.S.												
													8 Tamper Proof, Aluminum												
													9 Fine Adjust, 1/2" Panel Mount, Aluminum												
													0 Fine Adjust, 1-3/8" Panel Mount, Aluminum												
													D Captured Vent, Tamper Proof, S.S.												
													<b>CGA Fitting</b>												
													Use 0 in all boxes to omit CGA.												
													Use "CUS" in boxes for customer supplied CGA.												
													<b>Gauges</b>												
													1 Include Gauges												
													2 Omit Gauges												
													3 Customer Supplied												
													<b>1st Stage Seat Material</b>												
													A Tefzel												
													H Kel-F												
													Q PEEK												
													<b>1st Stage Cv Flow</b>												
													3 0.06												
													5 0.2												
													C 0.025												
													<b>2nd Stage Seat Material</b>												
													A Tefzel												
													H Kel-F												
													Q PEEK												
													<b>2nd Stage Cv Flow</b>												
													3 0.06												
													5 0.2												
													C 0.025												
C C 2 -																									

# PORT LOCATIONS (CYLINDER REGULATORS)

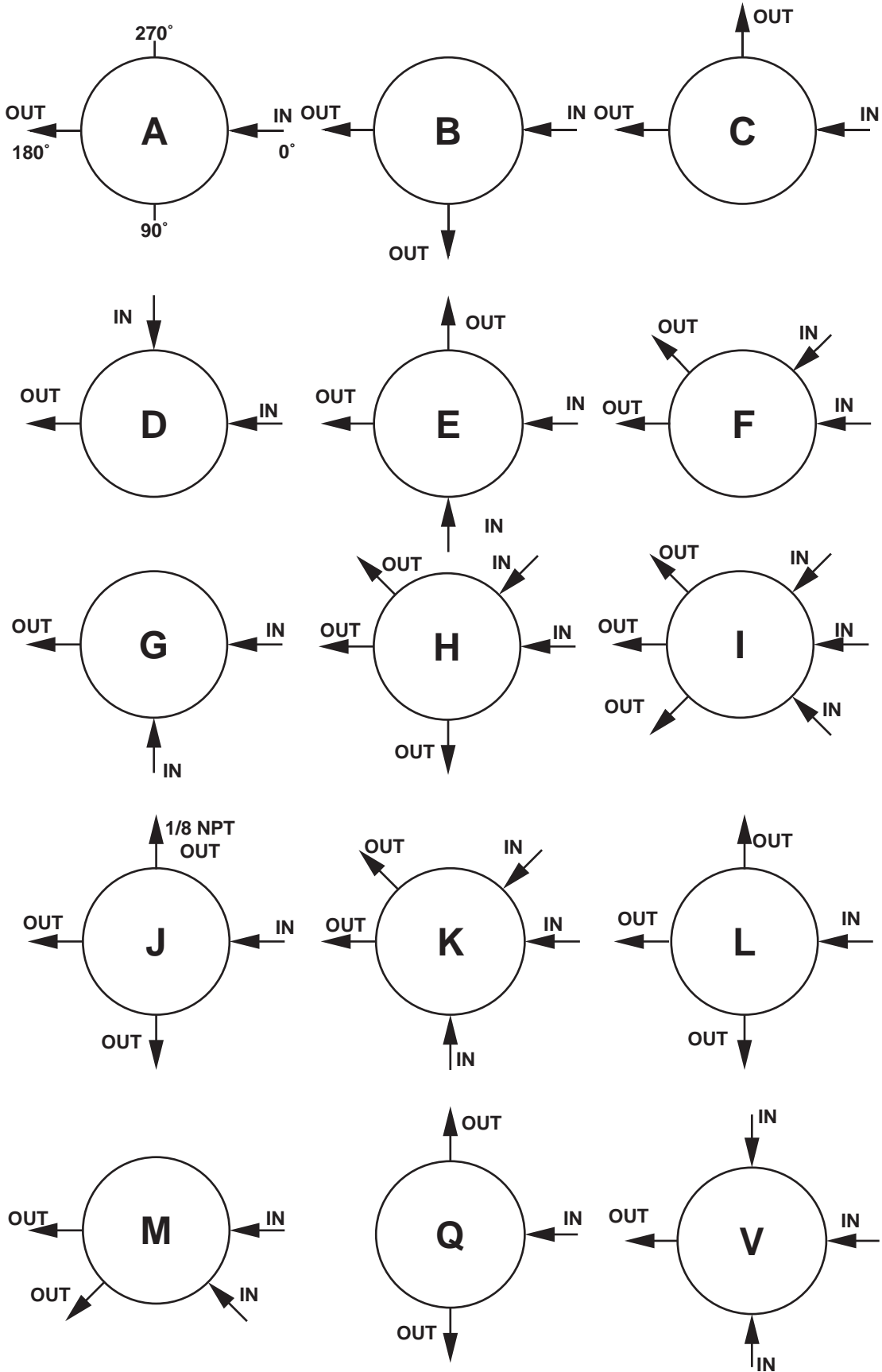

LOCATION OF PORTS FROM TOP VIEW