



PR50 Series

Inlet & Outlet to 10,000 psig

High Pressure Self-Venting Pressure Regulator

Features

- Balanced Poppet Design
- Self-Relieving Captured Vent
- Low Operating Torque

Applications

- High Pressure Testing
- Purging & Charging
- Research Laboratories
- Chemical/Petroleum Plants
- Manufacturing Processes

Technical Data

Body Construction Materials:	• Brass, 303 or 316 Stainless Steel
Seat Materials:	• Kel-F or Vespel®
Seal Materials:	• Buna N, Ethylene Propylene, Neoprene or Viton®
Port Sizes:	• 1/4", 1/2" NPT; 1/2" Male Tube; or 1/2" British Parallel Pipe
Pressure Ratings:	• Inlet – CRES to 10,000 psig (690 BAR) Brass to 6,000 psig (414 BAR) • Outlet – 40 to 10,000 psig (2.7 to 690 BAR)
Temperature Range:	• -40° F to +165° F (-40° C to +74° C)
Flow Capacity:	• $C_v = 0.30$ • ESEOD = 0.13"
Weight:	• 8 lbs
Leakage:	• Bubble Tight (Air)

NOTE: Proper filtration is recommended to prevent damage to sealing surfaces.

How It Works

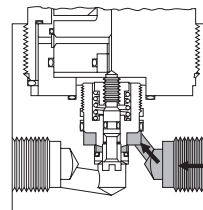

CLOSED

Balanced Poppet is spring loaded against the seat. When full upstream pressure is applied, a slightly unbalanced force is developed which enhances sealing.

REGULATING

As downstream process demands flow, the pressure acting on the piston decays, allowing the adjusting spring force to push the piston down. This unseats the poppet, allowing flow to begin and pressure under the piston to increase until balance is achieved between adjusting spring force and downstream pressure. This condition continues until process demand ceases. At this point, increasing pressure overcomes spring force, moving the piston up, allowing the poppet to close.

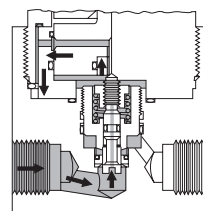
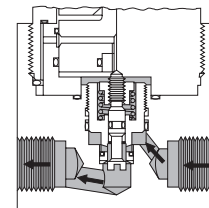

VENTING

If the downstream pressure should increase beyond regulation set point, or handle is backed off to decrease regulated pressure level, downstream pressure will vent through the piston and guide to the vent port. The pressure load from the piston overcomes the "set" spring load and moves the piston upward. The poppet is thereby unseated to allow venting flow. As pressure decreases under the piston the reverse action occurs and the vent seat is closed off.

2301 Wardlow Circle
P.O. Box 3300
Corona, CA 92878
tel 909.270.6200
fax 909.270.6201
www.circle-seal.com
sales@circle-seal.com

PR50 Series

Inlet & Outlet to 10,000 psig

How to Order

(Repair Kit) ————— **R/**

BASIC MODEL NUMBER ————— **PR52**
PR50 Series

MAX. OUTLET PRESSURE * ————— **U 1 1 1 2 G**

52 – 40 to 400 psig (248 BAR)
53 – 80 to 800 psig (138 BAR)
54 – 150 to 1,500 psig (50 BAR)
55 – 300 to 3,000 psig (14 BAR)
56 – 450 to 4,500 psig (414 BAR)
57 – 600 to 6,000 psig (414 BAR)
58 – 1,000 to 10,000 psig (414 BAR)

BODY MATERIAL —————

B – Brass
U – 316 Stainless Steel
T – 303 Stainless Steel

INLET & OUTLET PORTS —————

1 – 1/4" NPT
2 – 1/2" NPT
3 – 1/2" Tube (MS55649-8)
4 – 1/2" British Parallel Pipe Thread
 (Vent Port 1/4" BPPT, Gauge Port 1/4" BS Taper Thd.)

OPTIONS

G – Gauges
N – 316 CRES Panel Nut

CLEANING LEVELS

1 – General Oxygen Service
2 – General Pneumatic Service
3 – Specify
4 – Precision Pneumatic Service

SEAT MATERIAL

1 – Vespel®
2 – Kel-F (Limited to 3,000 psi Inlet Pressure, 52 thru 55 only)

SEAL MATERIAL

0 – Ethylene Propylene
1 – Neoprene (Std.)
3 – Viton® (Std. For O2 Service)
4 – Buna N

* For best regulating characteristics use only within 10% to 90% of maximum outlet pressure range. Either liquid or gas is handled equally well by the PR50 Series. No modification is required to convert from gas service to liquid. Seals and seats are available for nearly all liquids or gases. The PR50 is not recommended for continuous liquid service.

Please consult your Circle Seal Controls Distributor, Representative or the factory for information on special connections, operating pressures and temperature ranges.

Vespel® and Viton® are register trademarks of Dupont.

Dimensions & Flow Curves

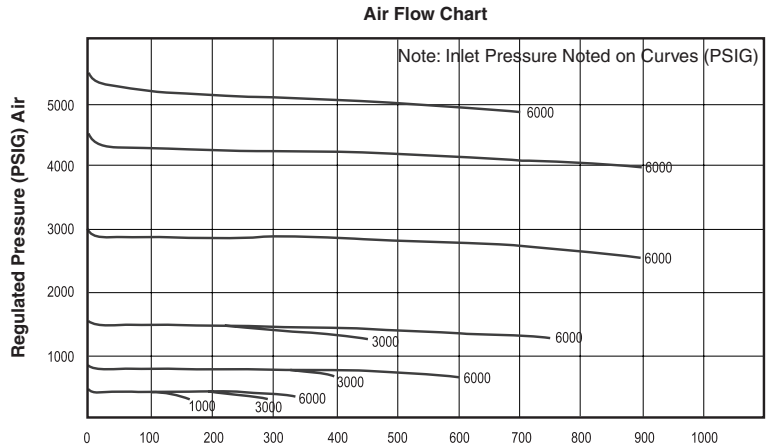
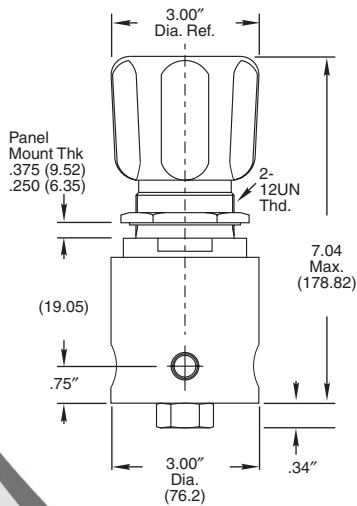

For Your Safety

It is the sole responsibility of the system designer and user to select products suitable for their specific application requirements and to ensure proper installation, operation and maintenance of these products. Material compatibility product ratings and application details should be considered in the selection. Improper selection or use of products described herein can cause personal injury