

Needle Valves

Yoke

Y Series

Pressures to 50,000 psi (3447 bar)

Autoclave Engineers' yoke valves are extra heavy-duty, plant grade instrument valves for industrial and severe service applications. Yoke valves feature low closing torque for ease of operation and are designed for use with Autoclave medium and high pressure tubing and fittings.

Yoke Valve Features:

- Tubing sizes from 9/16" to 1".
- Rising stem/barstock body design.
- Non-rotating stem prevents stem/seat galling.
- Metal-to-metal seating achieves bubble-tight shut-off, longer stem/seat life in abrasive flow, greater durability for repeated on/off cycles and excellent corrosion resistance.
- PTFE (Teflon) encapsulated packing provides dependable stem and body sealing.
- Non-rotating stem prevents stem/seat galling
- Stem sleeve and packing gland materials have been selected to achieve extended thread cycle life and reduced handle torque.
- Choice of Vee or Regulating stem tips.
- Available in two body patterns.
- Optional materials for cryogenic and other applications.

Autoclave valves are complemented by a complete line of fittings, tubing, and accessories.



**Autoclave
Engineers** 

Fluid Components
Division of Snap-tite, Inc.

www.autoclaveengineers.com

Valve Series - Y Series

Pressures to 50,000 psi (3447 bar)



Tube Outside Diameter Size Inches	Connection Type	Orifice Size Inches (mm)	Rated C_V *	Pres./Temp. Rating psi (bar) @ Room Temperature**
9/16	562C	0.188 (4.76)	0.66	50,000 (3447)
3/4	S750CX	0.438 (11.13)	2.41	15,000 (1034)
1	S1000CX	0.562(14.27)	3.15	15,000 (1034)
1	1000C43	0.375 (9.53)	2.3	43,000 (2965)

Notes:

* C_V values shown are for 2-way straight valve pattern. For 2-way angle patterns, increase C_V value 50%.

**For complete temperature ratings see pressure/temperature rating guide in Technical Information section.

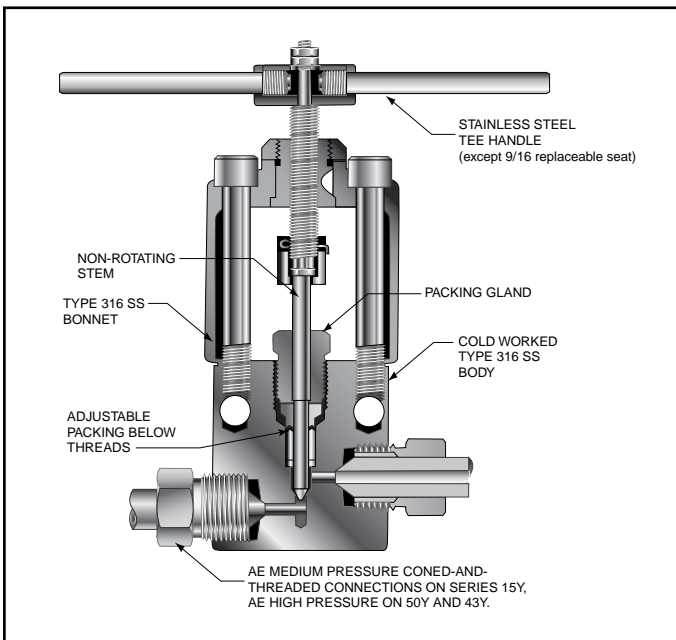

Generalized Flow Coefficient Curves (C_V)

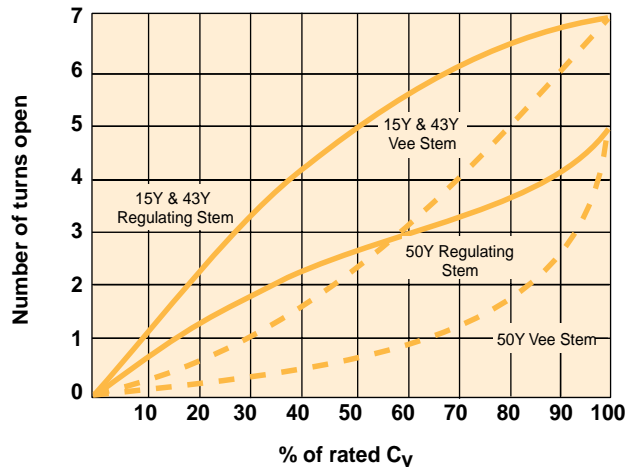

To ensure proper fit use Autoclave tubing

Ordering Procedure

For complete information on available stem types, optional connections and additional valve options, see Needle Valve Options section or contact your Sales Representative. The Y Series valves are furnished complete with connection components, unless otherwise specified.

Typical catalog number: **50Y9071**

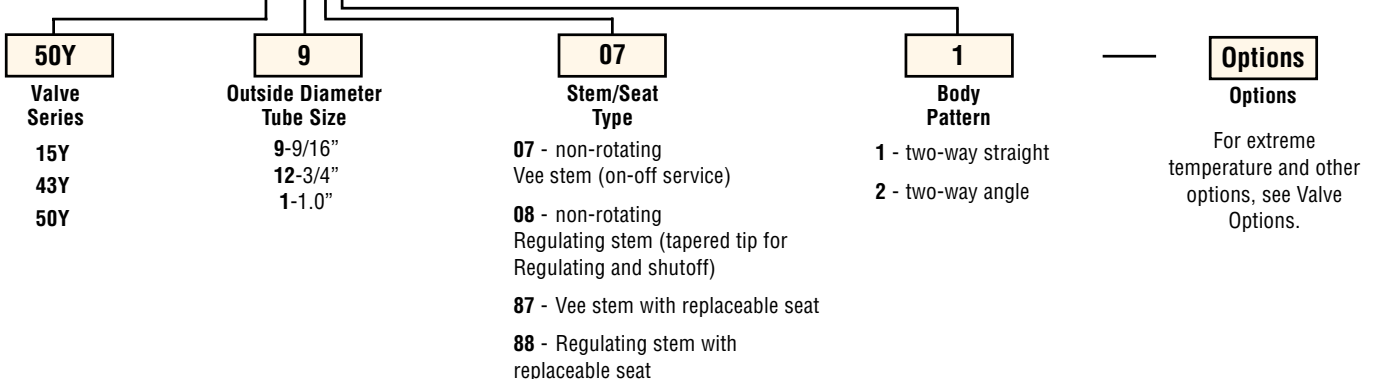

All general terms and conditions of sale, including limitations of our liability, apply to all products and services sold.

Valve Options

Extreme Temperatures

Standard Autoclave valves with Teflon packing may be operated to 450°F (232°C). High temperature packing is available for service from 0°F (-17.8°C) to 600°F (316°C) by adding the following suffixes to catalog order number.

TG standard valve with Teflon glass packing to 600°F (316°C).

B standard valve with cryogenic trim materials and Teflon packing to -100°F (-73°C).

Valve Maintenance

Repair Kits: add "R" to the front of valve catalog number for proper repair kit.
(Example: **R50Y9071**)

Valve Bodies: Valve bodies are available. Order using the eight (8) digit part number found on the valve drawing or contact your Sales Representative for information.

Consult your Autoclave representative for pricing on repair kits and valve bodies. Refer to the Tools, Installation, Operation and Maintenance section for proper maintenance procedures.

Catalog Number	Stem Type	Outside Diameter Tube	Orifice Diameter	Dimensions - inches (mm)												Block Thickness	Valve Pattern
				A	B	C	D	D ₁	E	F	G	G ₁	H*	M	N		

2-Way Straight

15Y12071	VEE	3/4	0.438	3.00	1.50	0.63	2.75	2.00	3.50	8.00		0.28	9.38	1.13	0.88	1.38	See Figure 1
15Y12081	REG	(19.05)	(11.13)	(76.20)	(38.10)	(15.88)	(69.85)	50.80	(88.90)	(203.20)		(7.11)	(238.25)	(28.58)	(22.23)	(34.93)	
15Y16071	VEE	1.00	0.562	4.13	2.06	0.63	3.25	3.25	4.13	10.25		0.28	10.00	1.50	1.13	1.75	
15Y16081	REG	(25.40)	(14.27)	(104.78)	(52.39)	(15.88)	(82.55)	82.55	(104.78)	(260.35)		(7.11)	(254.00)	(38.10)	(28.58)	(44.45)	
43Y16071	VEE	1.00	0.375	4.13	2.07	0.72	3.00	2.25	3.88	10.25		0.28	9.56	1.50	1.00	1.75	
43Y16081	REG	(25.40)	(9.53)	(104.90)	(52.45)	(18.29)	(76.20)	57.15	(98.55)	(260.35)		(7.11)	(242.82)	(38.10)	(25.40)	(44.45)	
50Y9071	VEE	9/16	0.188	3.00	1.50	0.56	2.56	2.00	3.25	13.00		0.50	8.69	1.13	0.88	1.38	
50Y9081	REG	(14.27)	(4.78)	(76.20)	(38.10)	(14.27)	(65.07)	50.80	(82.55)	(330.20)		(12.70)	(220.73)	(28.58)	(22.23)	(34.93)	

2-Way Angle

15Y12072	VEE	3/4	0.438	3.00	1.50	0.63	2.00		3.75	8.00		0.28	9.63	1.13	0.88	1.38	See Figure 2
15Y12082	REG	(19.05)	(11.13)	(76.20)	(38.10)	(15.88)	50.80		(95.25)	(203.20)		(7.11)	(244.48)	(28.58)	(22.23)	(34.93)	
15Y16072	VEE	1.00	0.562	4.13	2.06	0.63	2.25		4.13	10.25		0.28	10.38	1.50	1.13	1.75	
15Y16082	REG	(25.40)	(14.27)	(104.90)	(52.39)	(15.88)	57.15		(104.78)	(260.35)		(7.11)	(263.53)	(38.10)	(28.58)	(44.45)	
43Y16072	VEE	1.00	0.375	4.13	2.07	0.72	2.25		5.12	10.25		0.28	10.80	1.50	1.00	1.75	
43Y16082	REG	(25.40)	(9.53)	(104.90)	(52.45)	(18.29)	57.15		(130.05)	(260.35)		(7.11)	(274.32)	(38.10)	(25.40)	(44.45)	
50Y9072	VEE	9/16	0.188	3.00	1.50	0.56	2.56		3.50	13.00		0.50	8.81	1.13	0.88	1.38	
50Y9082	REG	(14.27)	(4.78)	(76.20)	(38.10)	(14.27)	65.07		(88.90)	(330.20)		(12.70)	(223.82)	(28.58)	(22.23)	(34.93)	

2-Way Angle/Replaceable Seat

15Y12872	VEE	3/4	0.438	3.00	1.50	0.63	1.94		4.00	8.00		0.28	11.31	1.13	0.88	1.38	See Figure 3
15Y12882	REG	(19.05)	(11.13)	(76.20)	(38.10)	(15.88)	(49.28)		(101.60)	(203.20)		(7.11)	(287.27)	(28.58)	(22.23)	(34.93)	
15Y16872	VEE	1.00	0.562	4.13	2.06	0.63	2.06		4.13	10.25		0.28	11.75	1.50	1.03	1.75	
15Y16882	REG	(25.40)	(14.27)	(104.78)	(52.39)	(15.88)	(52.32)		(104.78)	(260.35)		(7.11)	(298.45)	(38.10)	(26.16)	(44.45)	
43Y16872	VEE	1.00	0.375	4.13	2.07	0.72	2.25		6.27	10.25		0.28	11.95	1.50	1.00	1.75	
43Y16882	REG	(25.40)	(9.53)	(104.78)	(52.45)	(18.29)	(57.15)		(159.26)	(260.35)		(7.11)	(303.53)	(38.10)	(25.40)	(44.45)	
50Y9872	VEE	9/16	0.188	3.00	1.50	0.56	2.00		3.38	4.00		0.28	12.12	1.13	1.06	1.38	
50Y9882	REG	(14.27)	(4.78)	(76.20)	(38.10)	(14.27)	(50.80)		(85.73)	(101.60)		(7.11)	(307.85)	(28.58)	(26.97)	(34.93)	

G - Bracket mounting hole size

* H Dimension is with stem in closed position.
All dimensions for reference only and subject to change.

For prompt service, Autoclave stocks select products. Consult factory.

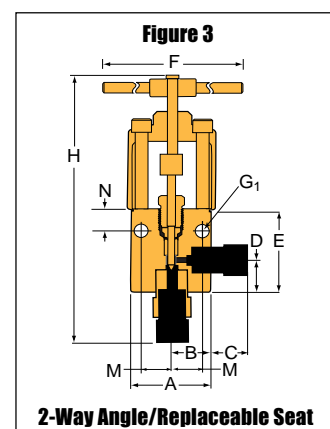
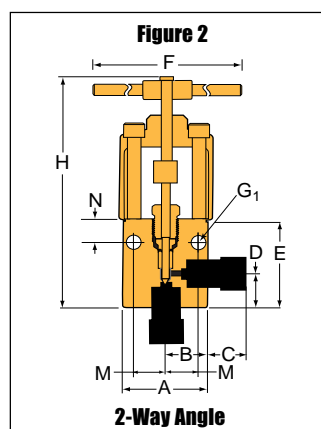
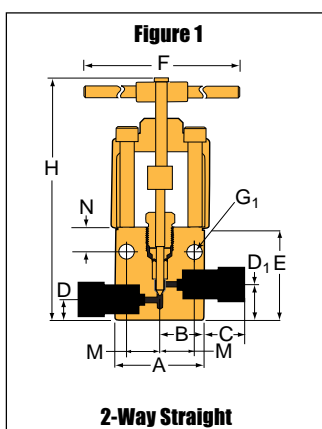

All general terms and conditions of sale, including limitations of our liability, apply to all products and services sold.

! WARNING !

FAILURE OR IMPROPER SELECTION OR IMPROPER USE OF THE PRODUCTS AND/OR SYSTEMS DESCRIBED HEREIN OR RELATED ITEMS CAN CAUSE DEATH, PERSONAL INJURY AND/OR PROPERTY DAMAGE.

This document and other information from Snap-tite, Inc., its subsidiaries and authorized distributors, provides product and/or system options for further investigation by users having technical expertise. It is important that you analyze all aspects of your application and review the information concerning the product or system in the current product catalog. Due to the variety of operation conditions and applications for these products or systems, the user, through its own analysis and testing, is solely responsible for making the final selection of the products and systems and assuring that all performance, safety and warning requirements of the application are met. The products described herein, including without limitation, product features, specifications, designs, availability and pricing, are subject to change by Snap-tite, Inc. and its subsidiaries at any time without notice.

**ISO-9001
Certified**

02-0119SE-1202



Industrial Estate
Whitemill-Wexford
Republic of Ireland
PH: 353-53-41566 FAX: 353-53-41582
e-mail: snaptite@snap-tite.iol.ie
www.snap-tite.com



Fluid Components
Division of Snap-tite, Inc.
8325 Hessinger Drive
Erie, Pennsylvania 16509-4679 USA
PH: 814-838-5700 FAX: 814-838-5811
e-mail: ae_sales@snap-tite.com
www.autoclaveengineers.com