

# Accessories - Universal Safety Heads

## Pressures to 110,000 psi (7584 bar)

**Safety Heads/Rupture Discs** - Safety Heads and Rupture Discs offer an economical and dependable relief port to guard against system over-pressure.

Autoclave Engineers offers universal safety heads in three series compatible in orifice size and maximum pressure rating with Autoclave Low Pressure, Medium Pressure and High Pressure valves, fittings and tubing.

**Autoclave Low Pressure Series SS:** Autoclave SpeedBite Ermeto-type tube connection, maximum rupture pressures to 11,500 psi ( 793 bar).

**Autoclave Medium Pressure Series SFCX:** Autoclave Medium-Pressure coned-and-threaded tube connection, maximum rupture pressures to 20,000 psi (1379 bar).

**Autoclave High Pressure Series FC:** Autoclave High Pressure coned-and-threaded tube connection, maximum rupture pressure to 110,000 psi (7584 bar).

The 3/16F style features a 3/16" blow-out diameter and a flat seat which can be ordered in pressure range from 200 to 27,000 psi (13.8 to 1862 bar).

The 1/4A style features a 1/4" blow-out diameter and an angular seat which can be ordered in pressures from 900 to 60,000 psi (62 to 4137 bar).

The 1/4F style features a 1/4" blow-out diameter and a flat seat which is used for pressure above 60,000 psi (4137 bar).

The 1/2F style features a 1/2" blow-out diameter and a flat seat which can be ordered in pressures from 500 to 10,000 psi (35 to 690 bar).

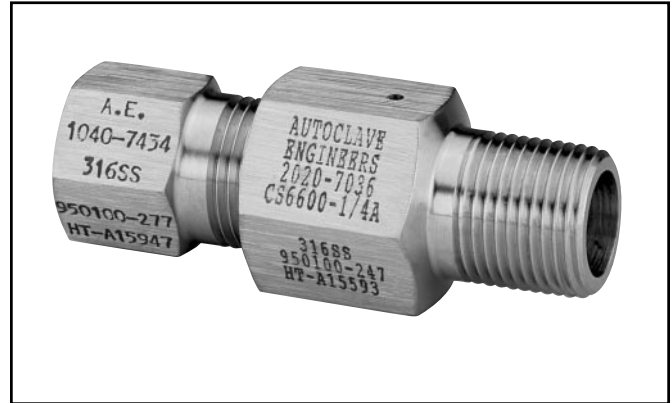

### Materials and Features

- Non-rotating double-cone plug design avoids galling and scoring of safety head or connection during installation. Reduces likelihood of leakage.
- Interchangeable hold-down rings permit use of several different sizes and types of rupture discs in a single safety head. Accommodates discs with rupture pressures as low as 90 psi (6.2 bar) and ranging to 60,000 psi (4137 bar) and above.
- Install in any standard Autoclave coupling, elbow, cross or tee, directly into a pressure vessel.
- Cold-worked Type 316 SS body hold down gland and plug, all series.
- Hold down rings are hardened tool steel.

*Consult Local Sales Representative for safety head assemblies rated above 60,000 psi (4137 bar).*

## Ordering Information

To order an Autoclave Universal Safety Head, use the catalog order number from table. ADD THE SIZE OF THE RUPTURE DISC YOU WANT AS A SUFFIX TO THE CATALOG NUMBER; SUCH AS CS6600-1/4A. Then order desired rupture discs from rupture disc section. (This is important since the disc size determines which hold-down ring will be furnished with the safety head.)

### Hold-down nut torque values

Torque@ Minimum Pressure		Torque@ Maximum Pressure		Rupture Disc inches	Hold-down Ring Part Number
Ft. lb. (N.m)	psi (bar)	Ft. lb. (N.m)	psi (bar)		
20 (27.1)	5,000 (345)	90 (122.0)	26,500 (1827)	3/16 Flat†	101A-0439
40 (54.2)	4,000 (276)	90 (122.0)	10,000 (690)	1/2 Flat	1020-7434
20 (27.1)	4,000 (276)	140 (189.8)	60,000 (4137)	1/4 Angle	102A-0439

† 3/16 flat seat disc cannot be used with safety head assemblies SS6600, SS8600 and CSX9600. Torque values for intermediate pressures may be linearly interpolated. Use minimum torque value for pressures lower than those shown.

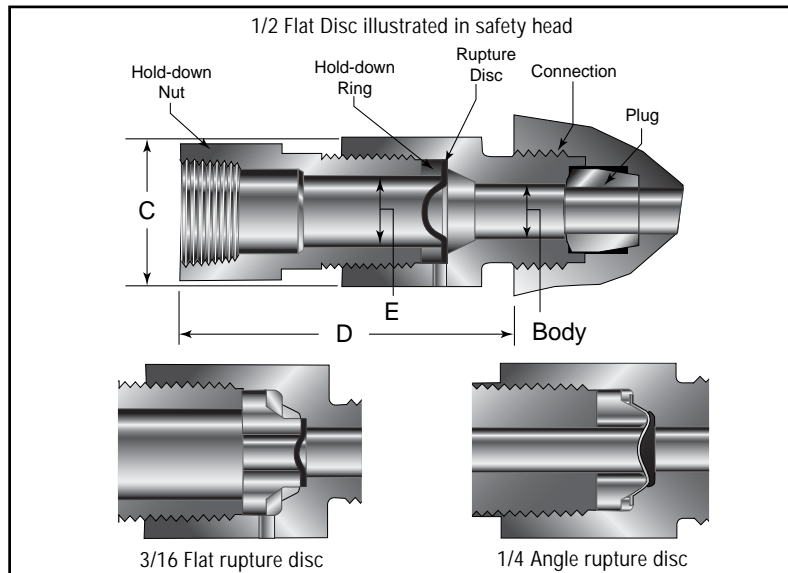
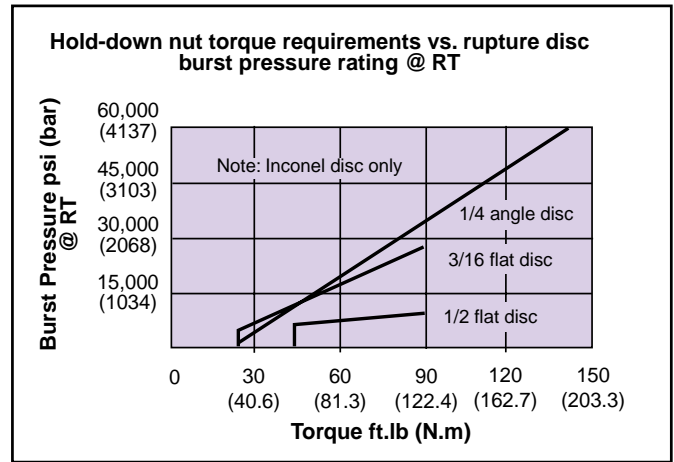

Catalog Number Without Disc	Body Part Number	Plug Part Number	Hold-down Gland Part Number	Fits Connection Type	Fitting Pressure Rating psi (bar)	Body Torque Ft.lb. (N.m)	Plug Orifice inches (mm)	Body Orifice inches (mm)	Rupture Disc Size inches (mm)			Dimensions inches (mm)	
									3/16F Port E*	1/4A Port E*	1/2F Port E*	C	D

### Low-Pressure

SS2600	2010-7035	101A-0434	3/16 & 1/2 Flat 1040-7434	W125	11,000 (758.4)	15 (20.3)	0.094 (2.39)	0.125 (3.15)	0.188 (4.78)	0.25 (6.35)	0.50 (12.7)	1.00 (25.4)	1.12 (28.45)
SS4600	2020-7035	102A-0434		SW250	11,500 (792.9)	15 (20.3)	0.125 (3.18)	0.250 (6.35)	0.188 (4.78)	0.25 (6.35)	0.50 (12.7)	1.00 (25.4)	1.12 (28.45)
SS6600	2030-7035	103A-0434	1/4 Angle 1030-0241	SW375	10,000 (690.0)	15 (20.3)	0.250 (6.35)	0.375 (9.53)	NA	0.25 (6.35)	0.50 (12.7)	1.00 (25.4)	1.12 (28.45)
SS8600	2040-7035	104A-0434		SW500	5,500 (379.2)	20 (22.1)	0.375 (9.53)	0.375 (9.53)	NA	0.25 (6.35)	0.50 (12.7)	1.00 (25.4)	1.12 (28.45)

Port E\* - Minimum disc blow-out diameter of hold down ring

Note: Interchangeable hold-down rings permit use of several different sizes and types of rupture disc in a single safety head. Series SS, CS, and CSX-1/4, 3/8 and 9/16 have stainless steel hold-down gland with tool steel hold-down ring.

Maximum pressure rating is based on the lowest rating of any component. Actual working pressure may be determined by tubing pressure rating, if lower.

All dimensions for reference only and subject to change.

For prompt service, Autoclave stocks select products. Consult your local representative.

All general terms and conditions of sale, including limitations of our liability, apply to all products and services sold.

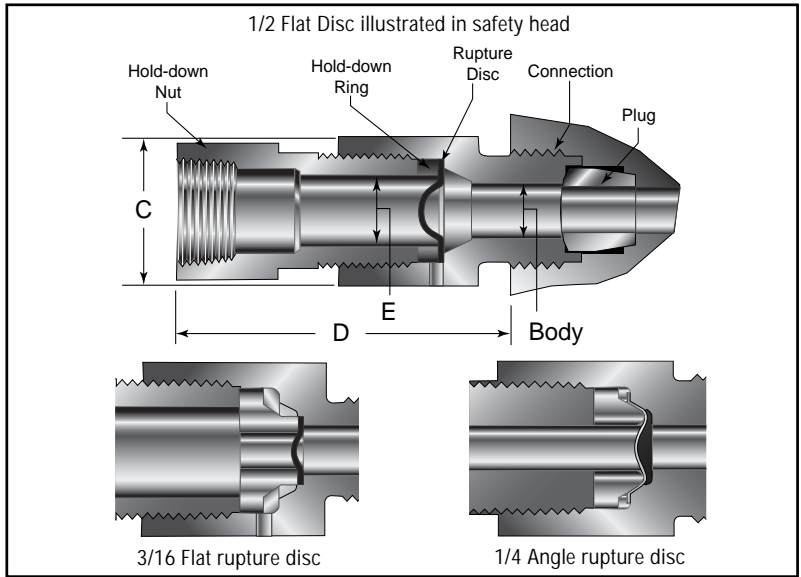

Catalog Number Without Disc	Body Part Number	Plug Part Number	Hold-down Gland Part Number	Fits Connection Type	Fitting Pressure Rating psi (bar)	Body Torque Ft.lb. (N.m)	Plug Orifice inches (mm)	Body Orifice inches (mm)	Rupture Disc Size inches (mm)			Dimensions inches (mm)	
									3/16F Port E*	1/4A Port E*	1/2F Port E*	C	D

**Medium-Pressure**

CSX4600	101A-1731	2010-7823	3/16 & 1/2 Flat 1040-7434	SF250CX	20,000 (1378.9)	15 (20.3)	0.094 (2.39)	0.141 (3.58)	0.188 (4.78)	0.25 (6.35)	0.50 (12.7)	1.00 (25.4)	2.19 (55.63)
CSX6600	102A-1731	2010-7844		SF375CX	20,000 (1378.9)	20 (27.1)	0.171 (4.34)	0.250 (6.35)	0.188 (4.78)	0.25 (6.35)	0.50 (12.7)	1.00 (25.4)	2.19 (55.63)
CSX9600	101A-0438	102A-0438	1/4 Angle 1030-0241	SF562CX	20,000 (1378.9)	30 (40.6)	0.312 (7.92)	0.375 (9.53)	NA	0.25 (6.35)	0.50 (12.7)	1.00 (25.4)	2.19 (55.63)

**High-Pressure**

CS4600	2010-7036	1030-4877	3/16 & 1/2 Flat 1040-7434	F250C	60,000 (4136.8)	20 (2.8)	0.082 (2.08)	0.125 (3.18)	0.188 (4.78)	0.25 (6.35)	0.50 (12.7)	1.00 (25.4)	2.25 (57.15)
CS6600	2020-7036	1030-6096		F375C	60,000 (4136.8)	40 (5.5)	0.125 (3.18)	0.219 (5.56)	0.188 (4.78)	0.25 (6.35)	0.50 (12.7)	1.00 (25.4)	2.25 (57.15)
CS9600	2030-7036	1030-6097		F562C	60,000 (4136.8)	80 (11.1)	0.188 (4.78)	0.281 (7.13)	0.188 (4.78)	0.25 (6.35)	0.50 (12.7)	1.19 (30.23)	2.25 (57.15)
40CS9600	2030-7036	101C-7192	1/4 Angle 1030-0241	F562C40	40,000 (2757.9)	80 (11.1)	0.250 (6.35)	0.281 (7.13)	NA	0.25 (6.35)	0.50 (12.7)	1.19 (30.23)	2.25 (57.15)

Port E\* - Minimum disc blow-out diameter of hold down ring

Note: Interchangeable hold-down rings permit use of several different sizes and types of rupture disc in a single safety head. Series SS, CS, and CSX-1/4, 3/8 and 9/16 have stainless steel hold-down gland with tool steel hold-down ring.

Maximum pressure rating is based on the lowest rating of any component. Actual working pressure may be determined by tubing pressure rating, if lower.

All dimensions for reference only and subject to change. For prompt service, Autoclave stocks select products. Consult your local representative.