

Needle Valves - SW Series

Pressures to 11,500 psi (793 bar)

Tube Outside Diameter Size Inches	Connection Type	Orifice Size Inches (mm)	Rated C_V^*	Pressure/Temperature Rating psi (bar) @ Room Temperature**
1/8	W125	Refer to 10V Series Valves	—	—
1/4	SW250	0.188 (4.77)	0.65	11,500 (793)
3/8	SW375	0.250 (6.35)	0.95	10,000 (690)
1/2	SW500	0.375 (9.52)	1.90	5,500 (379)

Notes:

* C_V values shown are for 2-way straight valve pattern. For 2-way angle patterns, increase C_V value 50%. (Based on water)

** For complete temperature ratings see pressure/temperature rating guide in Technical Information section.

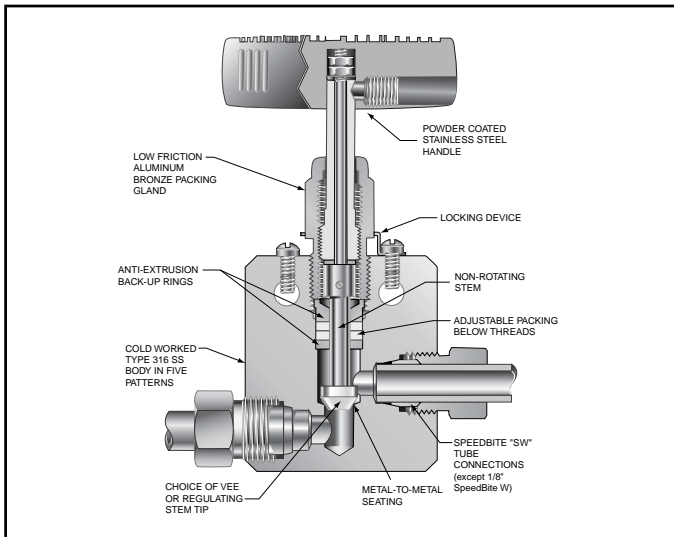

To ensure proper fit use Autoclave tubing

Generalized Flow Coefficient Curves (C_V)

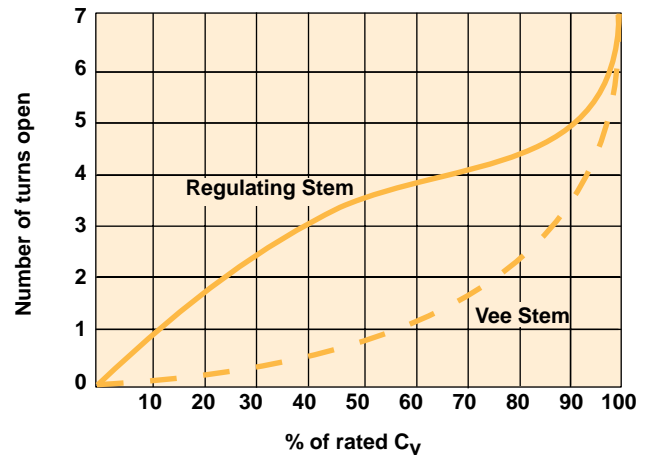

Ordering Procedure

For complete information on available stem types, optional connections and additional valve options, see Needle Valve Options section or contact your Sales Representative. SW Series valves are furnished complete with connection components, unless otherwise specified.

Typical catalog number: **SW4071**

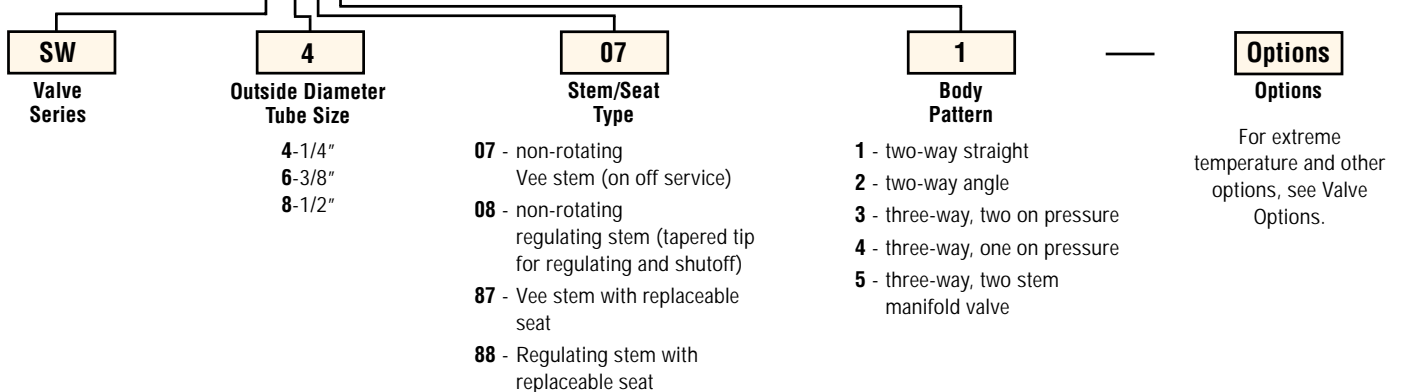

All general terms and conditions of sale, including limitations of our liability, apply to all products and services sold.

Valve Options

Extreme Temperatures

Standard Autoclave valves with Teflon packing may be operated to 450°F (232°C). High temperature packing and/or extended stuffing box are available for service from 0°F (-17.8°C) to 650°F (343°C) by adding the following suffixes to catalog order number.†

TG standard valve with Teflon glass packing to 600°F (316°C).

GY standard valve with graphite braided yarn packing to 650°F (343°C).

† Autoclave Engineers does not recommend compression sleeve connections below 0 F (-17.8 C) or above 650 F (343 C). For additional valve options, contact your Sales Representative.

Valve Maintenance

Repair Kits: add "R" to the front of valve catalog number for proper repair kit. (Example: **RSW4071**)

Valve Bodies: Valve bodies are available. Order using the eight (8) digit part number found on the valve drawing or contact your Sales Representative for information.

Consult your Autoclave representative for pricing on repair kits and valve bodies. Refer to the Tools, Installation, Operation and Maintenance section for proper maintenance procedures.

Catalog Number	Stem Type	Outside Diameter Tube	Orifice Diameter	Dimensions - inches (mm)												Block Thickness	Valve Pattern
				A	B	C	D	D ₁	E	F	G	G ₁	H*	M	N		

2-Way Straight

SW4071	VEE	1/4	0.187	2.00	1.00	0.38	1.62	1.19	2.00	3.00	0.75	0.22	4.50	0.62	0.38	0.75	See Figure 1
SW4081	REG	(6.35)	(4.75)	(50.80)	(25.40)	(9.65)	(41.15)	(30.23)	(50.80)	(76.20)	(19.05)	(5.59)	(114.30)	(15.75)	(9.65)	(19.05)	
SW6071	VEE	3/8	0.250	2.00	1.00	0.47	1.62	1.19	2.00	3.00	0.75	0.22	4.50	0.62	0.38	0.75	
SW6081	REG	(9.53)	(6.35)	(50.80)	(25.40)	(11.94)	(41.15)	(30.23)	(50.80)	(76.20)	(19.05)	(5.59)	(114.30)	(15.75)	(9.65)	(19.05)	
SW8071	VEE	1/2	0.375	2.50	1.25	0.53	2.38	1.75	2.88	4.00	1.00	0.34	5.95	0.69	0.50	1.00	
SW8081	REG	(12.70)	(9.53)	(63.50)	(31.75)	(13.46)	(60.45)	(44.45)	(73.15)	(101.60)	(25.40)	(8.64)	(151.37)	(17.53)	(12.70)	(25.40)	

2-Way Angle

SW4072	VEE	1/4	0.187	2.00	1.00	0.38	1.19		2.43	3.00	0.75	0.22	5.00	0.62	0.38	0.75	See Figure 2
SW4082	REG	(6.35)	(4.75)	(50.80)	(25.40)	(9.65)	(30.23)		(61.72)	(76.20)	(19.05)	(5.59)	(127.00)	(15.75)	(9.65)	(19.05)	
SW6072	VEE	3/8	0.250	2.00	1.00	0.47	1.19		2.19	3.00	0.75	0.22	5.00	0.62	0.38	0.75	
SW6082	REG	(9.53)	(6.35)	(50.80)	(25.40)	(11.94)	(30.23)		(55.63)	(76.20)	(19.05)	(5.59)	(127.00)	(15.75)	(9.65)	(19.05)	
SW8072	VEE	1/2	0.375	2.50	1.25	0.53	1.75		3.38	4.00	1.00	0.34	6.45	0.69	0.50	1.00	
SW8082	REG	(12.70)	(9.53)	(63.50)	(31.75)	(13.46)	(44.45)		(85.85)	(101.60)	(25.40)	(8.64)	(163.83)	(17.53)	(12.70)	(25.40)	

3-Way / 2 on Pressure

SW4073	VEE	1/4	0.187	2.00	1.00	0.38	1.62	1.19	2.62	3.00	0.75	0.22	5.18	0.62	0.38	0.75	See Figure 3
SW4083	REG	(6.35)	(4.75)	(50.80)	(25.40)	(9.65)	(41.15)	(30.23)	(66.55)	(76.20)	(19.05)	(5.59)	(131.57)	(15.75)	(9.65)	(19.05)	
SW6073	VEE	3/8	0.250	2.00	1.00	0.47	1.62	1.19	2.62	3.00	0.75	0.22	5.13	0.62	0.38	0.75	
SW6083	REG	(9.53)	(6.35)	(50.80)	(25.40)	(11.94)	(41.15)	(30.23)	(66.55)	(76.20)	(19.05)	(5.59)	(130.30)	(15.75)	(9.65)	(19.05)	
SW8073	VEE	1/2	0.375	2.50	1.25	0.53	2.38	1.75	3.62	4.00	1.00	0.34	6.70	0.69	0.50	1.00	
SW8083	REG	(12.70)	(9.53)	(63.50)	(31.75)	(13.46)	(60.45)	(44.45)	(91.95)	(101.60)	(25.40)	(8.64)	(170.18)	(17.53)	(12.70)	(25.40)	

G - Packing gland mounting hole drill size
G₁ - Bracket mounting hole size
Panel mounting drill size: 0.22" all valves.

* H Dimension is with stem in closed position.
All dimensions for reference only and subject to change.

For prompt service, Autoclave stocks select products. Consult factory.

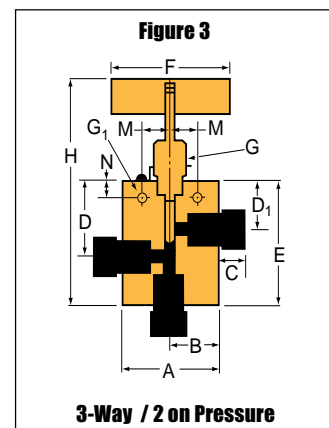
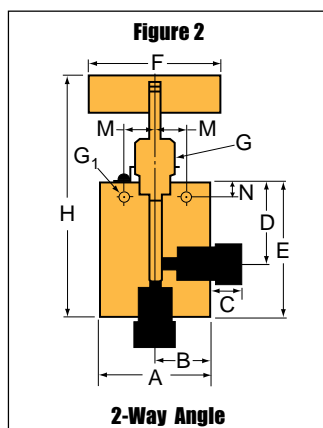
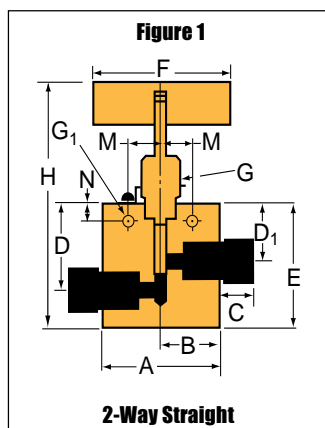

Catalog Number	Stem Type	Outside Diameter Tube	Orifice Diameter	Dimensions - inches (mm)												Block Thickness	Valve Pattern
				A	B	C	D	D ₁	E	F	G	G ₁	H*	M	N		

3-Way / 1 on Pressure

SW4074	VEE	1/4	0.187	2.00	1.00	0.38	1.19		2.43	3.00	0.75	0.22	5.00	0.62	0.38	0.75	See Figure 4
SW4084	REG	(6.35)	(4.75)	(50.80)	(25.40)	(9.65)	(30.23)		(61.72)	(76.20)	(19.05)	(5.59)	(127.00)	(15.75)	(9.65)	(19.05)	
SW6074	VEE	3/8	0.250	2.00	1.00	0.47	1.19		2.43	3.00	0.75	0.22	5.00	0.62	0.38	0.75	
SW6084	REG	(9.53)	(6.35)	(50.80)	(25.40)	(11.94)	(30.23)		(61.72)	(76.20)	(19.05)	(5.59)	(127.00)	(15.75)	(9.65)	(19.05)	
SW8074	VEE	1/2	0.375	2.50	1.25	0.53	1.75		3.38	4.00	1.00	0.34	6.45	0.69	0.50	1.00	
SW8084	REG	(12.70)	(9.53)	(63.50)	(31.75)	(13.46)	(44.45)		(85.85)	(101.60)	(25.40)	(8.64)	(163.83)	(17.53)	(12.70)	(25.40)	

2-Way Angle / Replaceable Seat

SW4872	VEE	1/4	0.187	2.00	1.00	0.38	1.19	1.88	2.25	3.00	0.75	0.22	5.75	0.62	0.38	0.75	See Figure 5
SW4882	REG	(6.35)	(4.75)	(50.80)	(25.40)	(9.65)	(30.23)	(47.75)	(57.15)	(76.20)	(19.05)	(5.59)	(146.05)	(15.75)	(9.65)	(19.05)	
SW6872	VEE	3/8	0.250	2.00	1.00	0.47	1.19	2.19	2.25	3.00	0.75	0.22	5.75	0.62	0.38	0.75	
SW6882	REG	(9.53)	(6.35)	(50.80)	(25.40)	(11.94)	(30.23)	(55.62)	(57.15)	(76.20)	(19.05)	(5.59)	(146.05)	(15.75)	(9.65)	(19.05)	
SW8872	VEE	1/2	0.375	2.50	1.25	0.53	1.75	2.50	3.25	4.00	1.00	0.34	7.51	0.69	0.50	1.00	
SW8882	REG	(12.70)	(9.53)	(63.50)	(31.75)	(13.46)	(44.45)	(63.50)	(82.55)	(101.60)	(25.40)	(8.64)	(190.75)	(17.53)	(12.70)	(25.40)	

3-Way / 2-Stem Manifold

SW4075	VEE	1/4	0.187	2.00	1.00	0.38	1.68	1.19	3.38	3.00	0.75	0.22	5.94	0.62	0.38	0.75	See Figure 6
SW4085	REG	(6.35)	(4.75)	(50.80)	(25.40)	(9.65)	(42.67)	(30.23)	(85.85)	(76.20)	(19.05)	(5.59)	(150.88)	(15.75)	(9.65)	(19.05)	
SW6075	VEE	3/8	0.250	2.00	1.00	0.47	1.68	1.19	3.38	3.00	0.75	0.22	5.94	0.62	0.38	0.75	
SW6085	REG	(9.53)	(6.35)	(50.80)	(25.40)	(11.94)	(42.67)	(30.23)	(85.85)	(76.20)	(19.05)	(5.59)	(150.88)	(15.75)	(9.65)	(19.05)	
SW8075	VEE	1/2	0.375	2.50	1.25	0.53	2.56	1.75	5.12	4.00	1.00	0.34	8.20	0.69	0.50	1.00	
SW8085	REG	(12.70)	(9.53)	(63.50)	(31.75)	(13.46)	(65.02)	(44.45)	(130.05)	(101.60)	(25.40)	(8.64)	(208.28)	(17.53)	(12.70)	(25.40)	

G - Packing gland mounting hole drill size
G₁ - Bracket mounting hole size
Panel mounting drill size: 0.22" all valves.

* H Dimension is with stem in closed position.
All dimensions for reference only and subject to change.

For prompt service, Autoclave stocks select products. Consult factory.

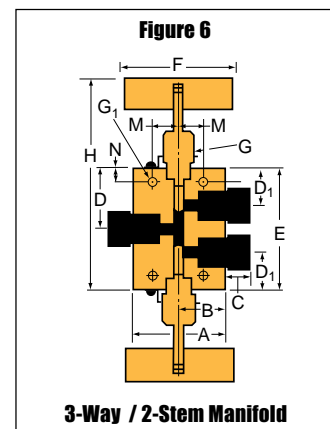
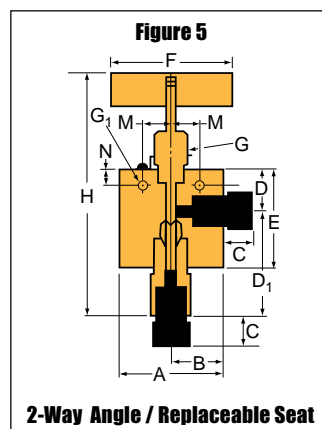
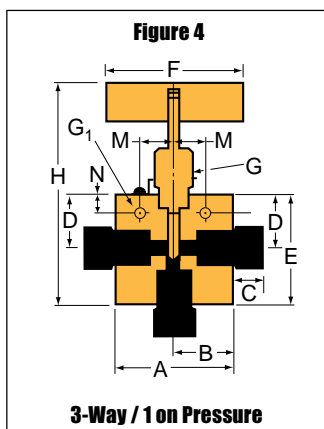

All general terms and conditions of sale, including limitations of our liability, apply to all products and services sold.

All general terms and conditions of sale, including limitations of our liability, apply to all products and services sold.