

"S" Series Needle/Gauge Valves



Autoclave Engineer's "S" Series needle and gauge valves have been engineered to provide reliable service and versatility in meeting specific process requirements. Valve heads are installed in hard and soft seat models of various body designs to accommodate the process control, flow measurement and mounting requirements of specific applications.

Standard valve assemblies with optional stems, seals and materials are available. Standard pressure rating is 6000 psi (414 bar) and 10,000 (690 bar) designed to 4 times safety factor.

**Autoclave
Engineers** 

Fluid Components
Division of Snap-tite, Inc.

Quality:

- ISO 9001
- 100% Pressure Tested
- Material Traceability
- Manufactured to NACE, ASME, DIN, etc.

Features:

- Bar Stock Construction
- Non-rotating Ball Stem
- Hard or Soft Seat
- Anti-blowout stem
- Bubble Tight Back Seal
- PTFE or Graphite Seals
- Oxygen Service Option
- Color-coded Valve Designation
- Metering Stem Option

Isolation Valve MNPT In FNPT Out
 Model Number SI-M4F4TXXSXS

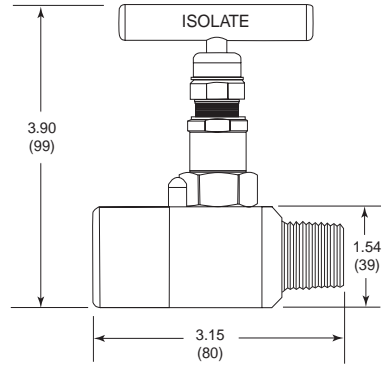
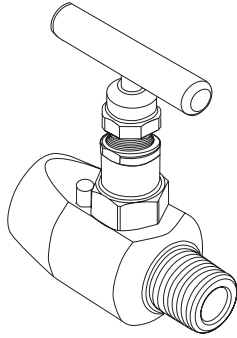
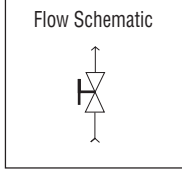

Female Panel Mounting Needle Valve
 Model Number SI-F4F4TXXSXS

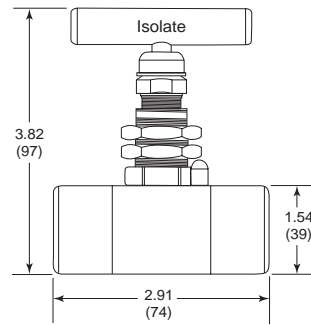
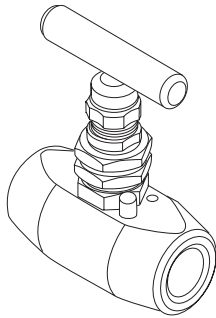
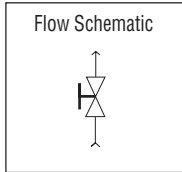

FNPT Screwed Bleeding Gauge Valve
 Model Number SI-F2F2TBMXS

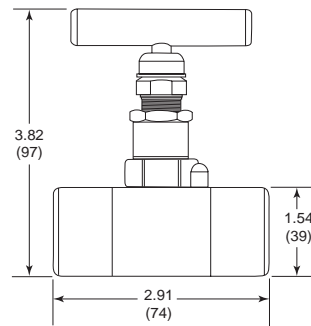
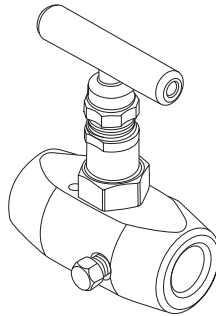
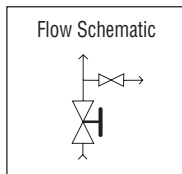

Isolation Valve with Tube Connection Ends
 Model Number SI-T8T8TXXSXS

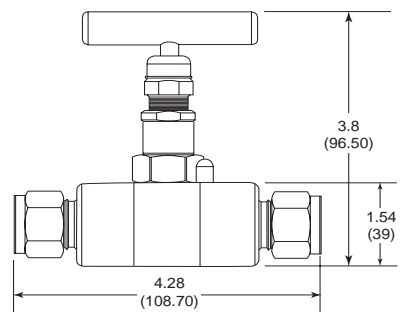
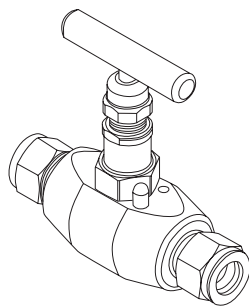
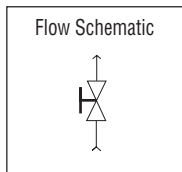

Series "S"

Valve Type

- I** - Isolation Valve
- 2R** - Remote Mount 2-Way
- IB** - Isolate with Union Bonnet
- IDB** - Double Isolate/Union Bonnet
- 2B** - 2-Way with Union Bonnet
- IDC** - Dual Channel Gauge Valve
- I2M** - Inline Two Way Manifold

Connection Inlet

- F** - Female NPT
- M** - Male NPT
- T** - Tube
- S** - Socket Weld
- B** - Butt Weld
- Contact Factory for Weld Ends

Connection Size

- 1** - 1/8"
- 2** - 1/4"
- 3** - 3/8"
- 4** - 1/2"
- 5** - 5/8"
- 6** - 3/4"
- 7** - 7/8"
- 8** - 1"

Connection Outlet

- F** - Female NPT
- M** - Male NPT
- T** - Tube
- S** - Socket Weld
- B** - Butt Weld
- Contact Factory for Weld Ends

Connection Size

- 1** - 1/8"
- 2** - 1/4"
- 3** - 3/8"
- 4** - 1/2"
- 5** - 5/8"
- 6** - 3/4"
- 7** - 7/8"
- 8** - 1"

Options

- 2** - Oxygen Cleaned
- PM** - Panel Mount
- 316** - All 316 SS
- ST** - Soft Seat PTEF
- SD** - Soft Seat Delrin
- 50** - Inlet Extension Adder
- 66** - Inlet Extension Adder
- 79** - Inlet Extension Adder
- 100** - Inlet Extension Adder
- 134** - Inlet Extension Adder
- 185** - Inlet Extension Adder
- HL** - Handle Lock

Trim

- M** - Metering Tip
- 4** - Monel 400
- 7** - 17-4 PH

Material

- S** - 316 SS
- L** - 316L NACE
- C** - C276
- M** - Monel 400
- I** - Inconel 718
- K** - Carb Steel

Pressure Rating

- X** - 6,000 psi Standard
- E** - 10,000 psi Design

Handle Type

- S** - Standard Tee
- T** - Tamper Proof Isolation
- V** - Tamper Proof Vent
- A** - All Tamper Proof
- K** - Knobs on all

Bleed/Vent Size

- X** - No Bleed
- M** - M8 Metric
- 2** - 1/4" NPT
- 4** - 1/2" NPT

Bleed/Vent Requirement

- X** - No Bleed
- B** - Single Bleed
- P** - Bleed & Plug
- V** - Vent

Packing Seal

- T** - Teflon
- G** - Graphite

G after the connection size means the connection is BSP Parallel
R after the connection size means the connection is BSP Taper
 eg: 1/2" NPT Male/Female Valve SI-M4F4TXXSXS
 1/2" BSP Parallel Male/Female Valve SI-M4GF4GTXXSXS

Lockable Female Panel Mounting Needle Valve

Model Number SI-F4F4TXXSXS-PMHL

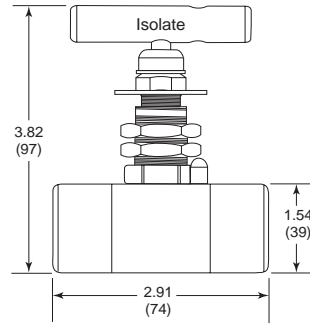
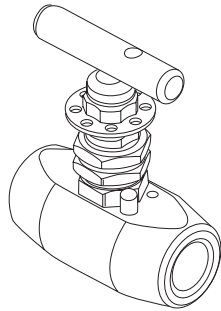
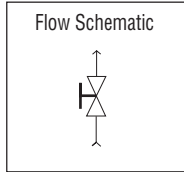

MNPT Remote Mount 2-Way Manifold

Model Number S2R-M4F4TVXSXS

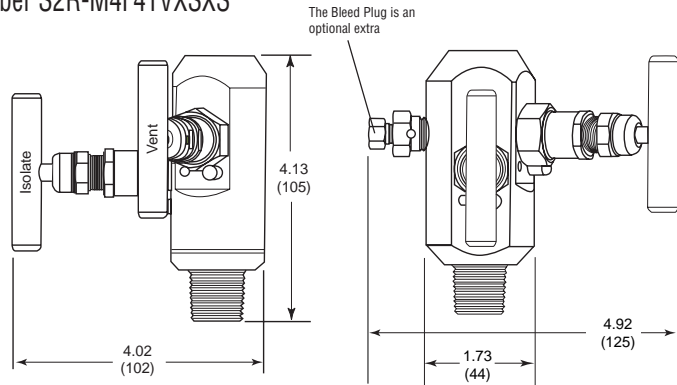
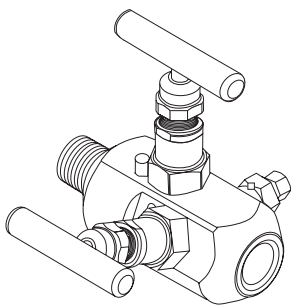
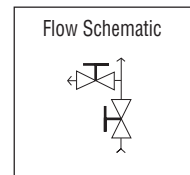

FNPT Union Bonnet Isolation Valve

Model Number SIB-F4F4TXXSXS

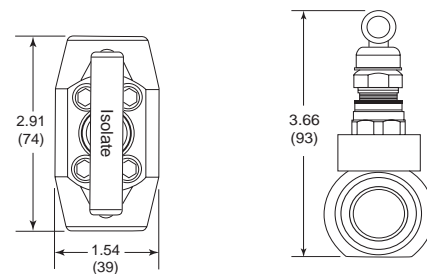
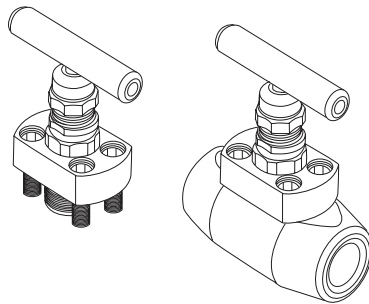
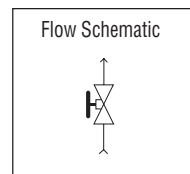

Double Isolating Union Bonnet Needle Valve

Model Number SIDB-F4B4TXXSXS

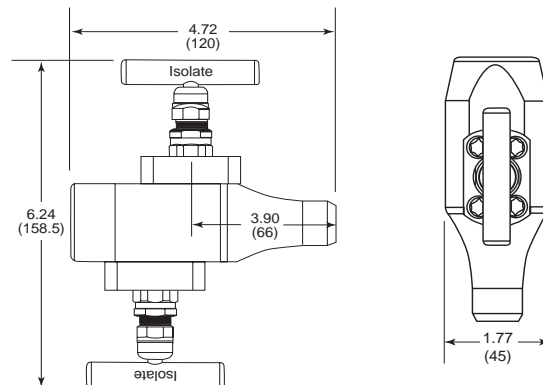
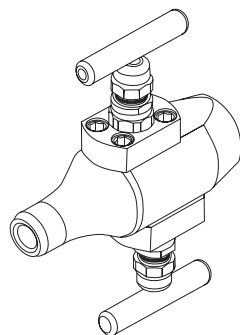
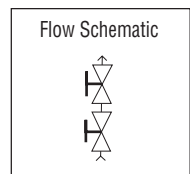

Dual Channel Gauge Valve

Model Number SIDC-M4F4TB2SXS

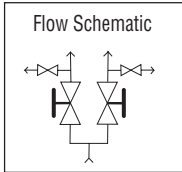
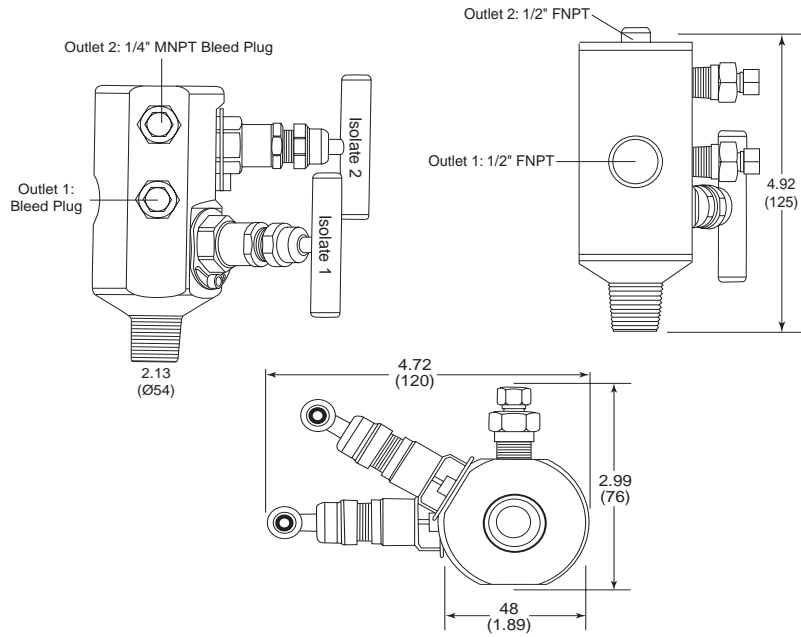
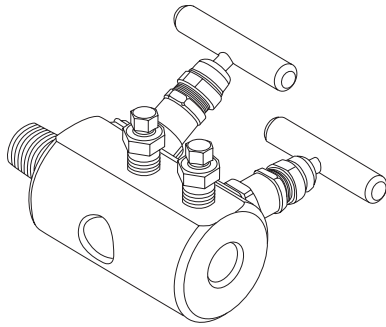

FNPT In-Line 2-Way Manifold

Model Number SI2M-F4F4TV2SXS

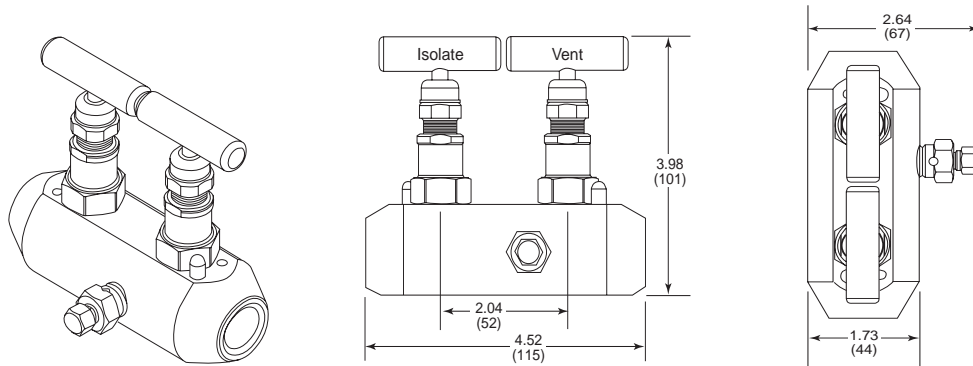
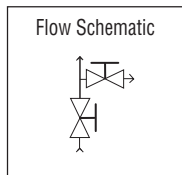

Male NPT Screwed Multiport Gauge Valve

Model Number SI-M4F4TP4SXS

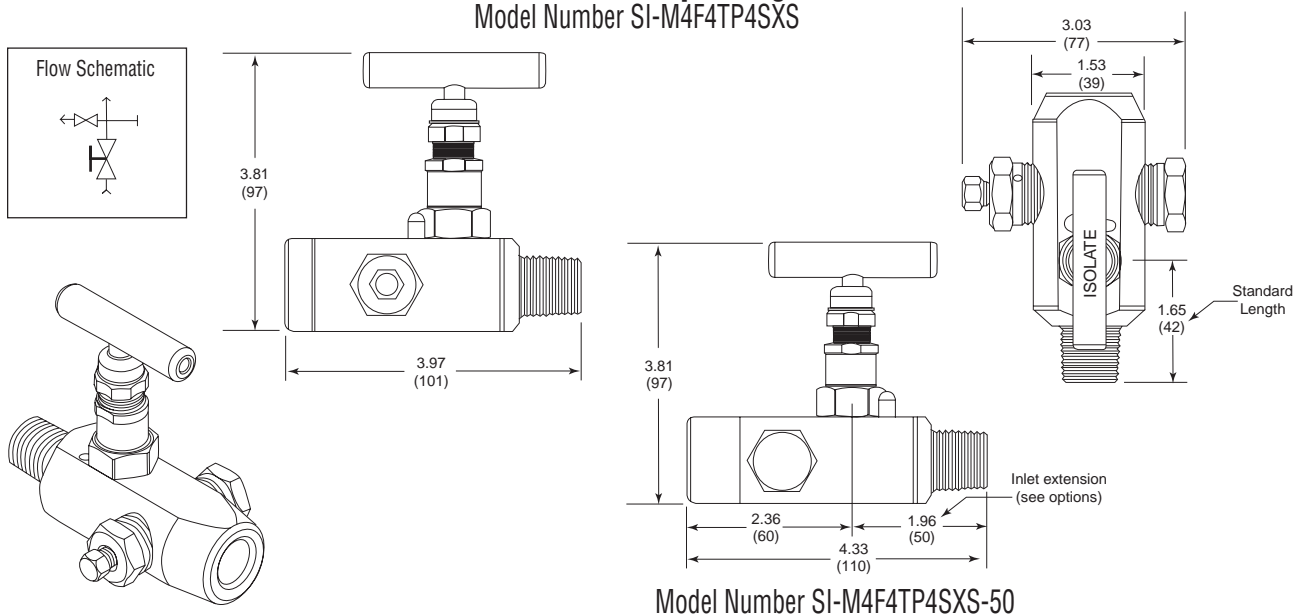
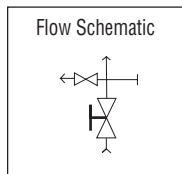

HP Secondary Valvehead (PA/SHPXH)

High Pressure Secondary Valvehead
PA/TSHPXH

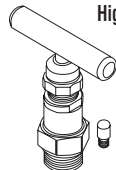

Pressure vs Temperature Curve
316 HP Valvehead

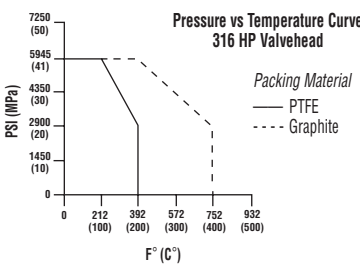

Notes: The stuffing box is self adjusting and requires no maintenance. In low pressure applications the pusher may need to be tightened by loosening the Locknut and turning the pusher clockwise one or two flats only, making sure that the **valve is in the open** positions.

Pressure Rating:
PTFE 6,000 psi (41.4 MPa) @ 212°F (100°C)
PTFE 6,000 psi (41.4 MPa) @ 392°F (200°C)

The High Pressure Secondary Valvehead has a safety margin of 4 times.

The S Series valve has a fully articulated, back-sealing, anti-blowout spindle whose pusher is grey in appearance because it is coated with a PTFE compound. Normally supplied with a T-Bar handle this unit is also available with a Tamper Proof drive mechanism.

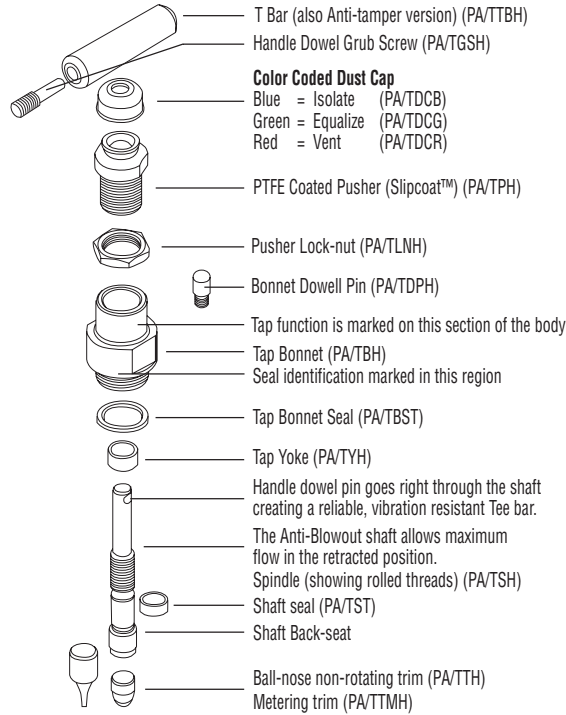

PA/TGSH	Grub Screw	H = 316SS
PA/TTBH	T-Bar	H = 316SS
PA/TDCR	Dust Cap	R-Red G-Green B-Blue
PA/TPH	Pusher	H = 316SS
PA/TLNH	Lock Nut + Spacer	H = 316SS
PA/TYH	Yoke	H = 316SS
PA/TSH	Spindle	H = 316SS
PA/TST	Shaft Seal	T-PTFE G-Graphite
PA/TBH	Bonnet	H = 316SS
PA/TDPH	Dowell Pin	H = 316SS
PA/TBST	Bonnet Seal	T-PTFE G-Graphite
PA/TTH	Trim	H = 316SS

Notes: ¹ The Tap Pusher is grey in appearance as it is plated Slipcoat, a PTFE lubricating coating.

The Valvehead (tap) is permanently engraved and also color coded. Details highlighted are the valve's function and the stuffing box seal material. An A number code (All element traceability or Heat Code) and the general material of construction is stamped on the main manifold body indicating wetted part materials. Information pertinent to the seals can be found in the general part number or by locating the letter T or G engraved on the Bonnet.

Flange seals will be supplied in the same material as the stuffing box seals.

! WARNING !

FAILURE OR IMPROPER SELECTION OR IMPROPER USE OF THE PRODUCTS AND/OR SYSTEMS DESCRIBED HEREIN OR RELATED ITEMS CAN CAUSE DEATH, PERSONAL INJURY AND PROPERTY DAMAGE.

This document and other information from Snap-tite, Inc., its subsidiaries and authorized distributors provide product and/or system options for further investigation by users having technical expertise. It is important that you analyze all aspects of your application and review the information concerning the product or system in the current product catalog. Due to the variety of operation conditions and applications for these products or systems, the user, through its own analysis and testing, is solely responsible for making the final selection of the products and systems and assuring that all performance, safety and warning requirements of the application are met.

The products described herein, including without limitation, product features, specifications, designs, availability and pricing, are subject to change by Snap-tite, Inc. and its subsidiaries at any time without notice.



Industrial Estate
Whitemill-Wexford
Republic of Ireland
PH: 353-53-41566 FAX: 353-53-41582
e-mail: ste_sales@snap-tite.com
www.snap-tite.com



Fluid Components
Division of Snap-tite, Inc.
8325 Hessinger Road
Erie, Pennsylvania 16509-4679 USA
PH: 814-8328-5700 FAX: 814-838-5811
e-mail: ae_sales@snap-tite.com
www.autoclaveengineers.com