

Needle Valves

Medium Pressure

SM Series

Pressures to 20,000 psi (1379 bar)

Since 1945 Autoclave Engineers has designed and built premium quality valves, fittings and tubing. This commitment to engineering and manufacturing excellence has earned Autoclave a reputation for reliable efficient product performance. Autoclave Engineers has long been established as the world leader in high pressure fluid handling components for the chemical/petrochemical, waterblast, research, and oil and gas industries.

Medium Pressure Valve Features:

- Largest-port valves available for medium pressure applications.
- Tubing sizes available from 1/4" to 1".
- Rising stem/barstock body design.
- Non-rotating stem prevents stem/seat galling.
- New one piece stem design permits ease of assembly and packing replacement.
- Metal-to-metal seating achieves bubble-tight shut-off, longer stem/seat life in abrasive flow, greater durability for repeated on/off cycles and excellent corrosion resistance.
- PTFE (Teflon) encapsulated packing provides dependable stem and body sealing.
- Stem sleeve and packing gland materials have been selected to achieve extended thread cycle life and reduced handle torque.
- Choice of Vee or Regulating stem tip.
- Available in five body patterns.

Autoclave valves are complemented by a complete line of fittings, tubing, check valves and line filters. The SM Series uses Autoclave's Medium pressure connection. The coned-and-threaded connection features orifice sizes to match the high flow characteristics of this series.

Note: SM Series replaces 20SC Series.



**Autoclave
Engineers**

Fluid Components
Division of Snap-tite, Inc.

www.autoclaveengineers.com

Needle Valves - SM Series
Medium Pressure

Needle Valves - SM Series

Pressures to 20,000 psi (1379 bar)



Tube Outside Diameter Size Inches	Connection Type	Orifice Size Inches (mm)	Rated C_V^*	Pressure/Temperature Rating psi (bar) @ Room Temperature**
1/4	SF250CX20	0.125 (3.18)	0.31	20,000 (1379)
3/8	SF375CX20	0.219 (5.56)	0.75	20,000 (1379)
9/16	SF562CX20	0.312 (7.92)	1.30	20,000 (1379)
3/4	SF750CX20	0.438 (11.13)	2.50	20,000 (1379)
1	SF1000CX20	0.562 (14.27)	4.40	20,000 (1379)
9/16	SF562CX10	0.359 (9.12)	1.75	10,000 (690)
3/4	SF750CX10	0.516 (13.10)	2.80	10,000 (690)
1	SF1000CX10	0.688 (17.48)	5.20	10,000 (690)

Notes:

* C_V values shown are for 2-way straight valve pattern. For 2-way angle patterns, increase C_V value 50%. (Based on water)

** For complete temperature ratings see pressure/temperature rating guide in Technical Information section.

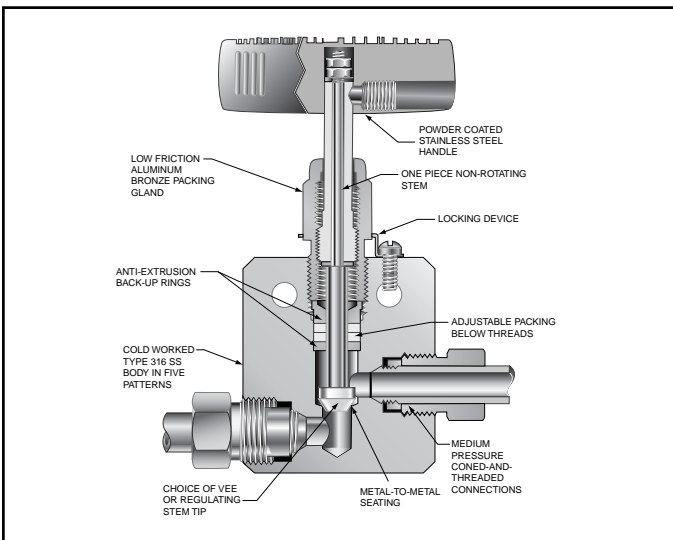

To ensure proper fit use Autoclave tubing

Generalized Flow Coefficient Curves (C_V)

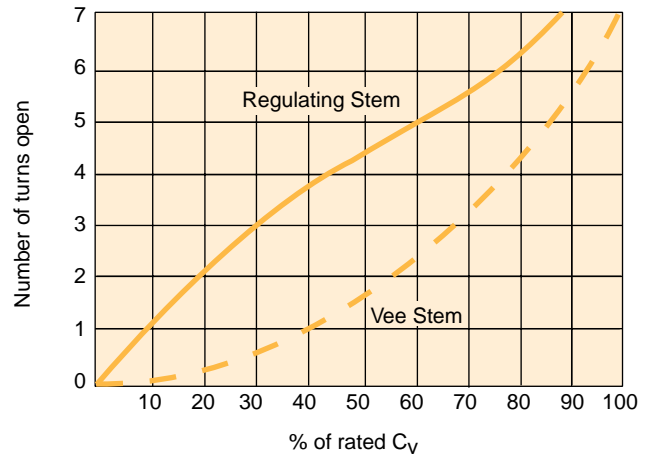

Ordering Procedure

For complete information on available stem types, optional connections and additional valve options, see Needle Valve Options section or contact your Sales Representative. 10SM and 20SM Series valves are furnished complete with connection components, unless otherwise specified.

Typical catalog number: **20SM4071**

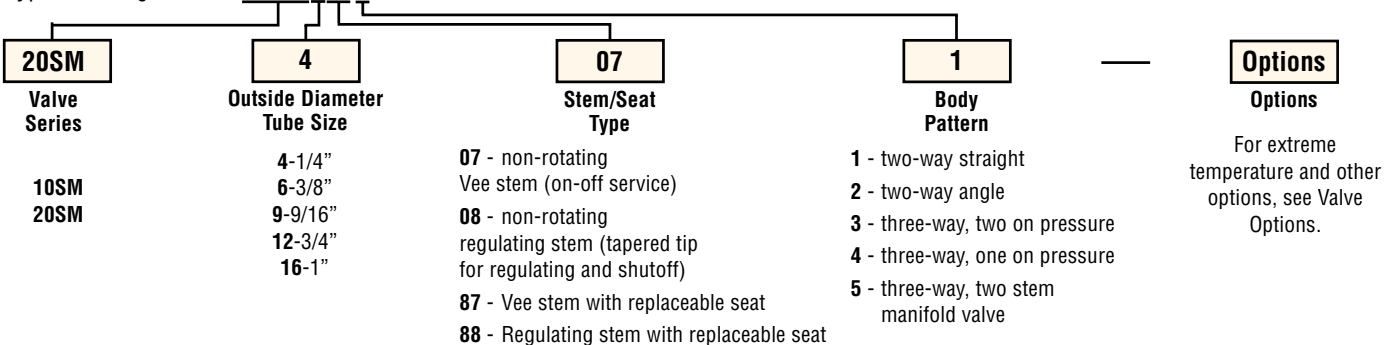

All general terms and conditions of sale, including limitations of our liability, apply to all products and services sold.

Valve Options

Extreme Temperatures

Standard Autoclave valves with Teflon packing may be operated to 450°F (232°C). High temperature packing and/or extended stuffing box are available for service from -423°F (-252°C) to 1200°F (649°C) by adding the following suffixes to catalog order number.

TG standard valve with Teflon glass packing to 600°F (316°C).

GY standard valve with graphite braided yarn packing to 800°F (427°C).

Note: 3/4" rated 8000 psi (552 bar) and 1" rated 6000 psi (412 bar)

maximum with graphite yarn packing.†

HT extended stuffing box valve with graphite braided yarn packing to 1200°F (649°C).

B standard valve with cryogenic trim materials and Teflon packing to -100°F (-73°C).

LT extended stuffing box valve with Teflon packing and cryogenic trim materials to -423°F (-252°C).

† This packing will affect the pressure rating. Refer to Technical Information section.

See needle valve options for stem and seat coating for erosive service.

Valve Maintenance

Repair Kits: add "R" to the front of valve catalog number for proper repair kit.
(Example: **R20SM4071**)

Valve Bodies: Valve bodies are available. Order using the eight (8) digit part number found on the valve drawing or contact your Sales Representative for information.

Consult your Autoclave representative for pricing on repair kits and valve bodies. Refer to the Tools, Installation, Operation and Maintenance section for proper maintenance procedures.

Note: Caution should be exercised in proper selection of medium pressure tubing based on actual operating conditions. Two tubing series available in some sizes: 10,000 psi (690 bar) and 20,000 psi (1380 bar).

Catalog Number	Stem Type	Outside Diameter Tube	Orifice Diameter	Dimensions - inches (mm)												Block Thickness	Valve Pattern
				A	B	C	D	D ₁	E	F	G	G ₁	H*	M	N		

2-Way Straight

20SM4071	VEE	1/4	0.125	2.00	1.00	0.38	1.19	1.62	2.00	3.00	0.75	0.22	4.69	0.62	0.38	0.75	See Figure 1
20SM4081	REG	(6.35)	(3.18)	(50.80)	(25.40)	(9.65)	(30.23)	(41.15)	(50.80)	(76.20)	(19.05)	(5.59)	(119.13)	(15.75)	(9.65)	(19.05)	
20SM6071	VEE	3/8	0.219	2.00	1.00	0.47	1.62	1.19	2.00	3.00	0.75	0.22	4.63	0.62	0.38	0.75	
20SM6081	REG	(9.53)	(5.56)	(50.80)	(25.40)	(11.94)	(41.15)	(30.23)	(50.80)	(76.20)	(19.05)	(5.59)	(117.48)	(15.75)	(9.65)	(19.05)	
20SM9071	VEE	9/16	0.312	2.50	1.25	0.53	2.38	1.75	2.88	4.00	1.00	0.34	5.93	0.69	0.50	1.00	
20SM9081	REG	(14.29)	(7.92)	(63.50)	(31.75)	(13.46)	(60.45)	(44.45)	(73.15)	(101.60)	(25.40)	(8.64)	(150.86)	(17.53)	(12.70)	(25.40)	
20SM12071	VEE	3/4	0.438	3.00	1.50	0.62	3.00	2.25	3.75	10.25	1.12	0.44	7.00	0.88	0.63	1.38	
20SM12081	REG	(19.05)	(11.13)	(76.20)	(38.10)	(15.75)	(76.20)	(57.15)	(95.25)	(260.35)	(28.45)	(11.18)	(177.80)	(22.35)	(16.00)	(35.05)	
20SM16071	VEE	1	0.562	4.12	2.06	0.63	3.75	2.81	4.63	10.25	1.62	0.56	9.00	1.25	1.13	1.75	
20SM16081	REG	(25.40)	(14.27)	(104.65)	(52.32)	(16.00)	(95.25)	(71.37)	(117.60)	(260.35)	(41.15)	(14.22)	(228.84)	(31.75)	(28.70)	(44.45)	
10SM9071	VEE	9/16	0.359	2.50	1.25	0.53	2.38	1.75	2.88	4.00	1.00	0.34	5.93	0.69	0.50	1.00	
10SM9081	REG	(14.29)	(9.12)	(63.50)	(31.75)	(13.46)	(60.45)	(44.45)	(73.15)	(101.60)	(25.40)	(8.64)	(150.86)	(17.53)	(12.70)	(25.40)	
10SM12071	VEE	3/4	0.516	3.00	1.50	0.62	3.00	2.25	3.75	10.25	1.12	0.44	7.00	0.88	0.63	1.38	
10SM12081	REG	(19.05)	(13.11)	(76.20)	(38.10)	(15.75)	(76.20)	(57.15)	(95.25)	(260.35)	(28.45)	(11.18)	(177.80)	(22.35)	(16.00)	(35.05)	
10SM16071	VEE	1	0.688	4.12	2.06	0.63	3.75	2.81	4.63	10.25	1.62	0.56	9.00	1.25	1.13	1.75	
10SM16081	REG	(25.40)	(17.48)	(104.65)	(52.32)	(16.00)	(95.25)	(71.37)	(117.60)	(260.35)	(41.15)	(14.22)	(228.84)	(31.75)	(28.70)	(44.45)	

G - Packing gland mounting hole drill size

G₁ - Bracket mounting hole size

Panel mounting drill size: 0.22" all valves.

* H Dimension is with stem in closed position.

All dimensions for reference only and subject to change.

For prompt service, Autoclave stock select products. Consult factory.

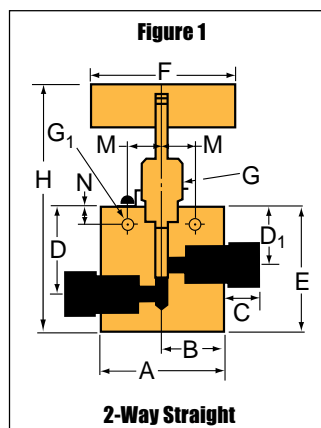

Catalog Number	Stem Type	Outside Diameter Tube	Orifice Diameter	Dimensions - inches (mm)												Block Thickness	Valve Pattern
				A	B	C	D	D ₁	E	F	G	G ₁	H*	M	N		

2-Way Angle

20SM4072	VEE	1/4	0.125	2.00	1.00	0.38	1.19		2.44	3.00	0.75	0.22	4.81	0.62	0.38	0.75	See Figure 2
20SM4082	REG	(6.35)	(3.18)	(50.80)	(25.40)	(9.65)	(30.23)		(61.90)	(76.20)	(19.05)	(5.59)	(122.25)	(15.75)	(9.65)	(19.05)	
20SM6072	VEE	3/8	0.219	2.00	1.00	0.47	1.19		2.44	3.00	0.75	0.22	4.81	0.62	0.38	0.75	
20SM6082	REG	(9.53)	(5.56)	(50.80)	(25.40)	(11.94)	(30.23)		(61.90)	(76.20)	(19.05)	(5.59)	(122.25)	(15.75)	(9.65)	(19.05)	
20SM9072	VEE	9/16	0.312	2.50	1.25	0.53	1.75		3.38	4.00	1.00	0.34	6.43	0.69	0.50	1.00	
20SM9082	REG	(14.29)	(7.92)	(63.50)	(31.75)	(13.46)	(44.45)		(85.85)	(101.60)	(25.40)	(8.64)	(163.56)	(17.53)	(12.70)	(25.40)	
20SM12072	VEE	3/4	0.438	3.00	1.50	0.62	2.25		4.25	10.25	1.12	0.44	7.50	0.88	0.63	1.38	
20SM12082	REG	(19.05)	(11.13)	(76.20)	(38.10)	(15.75)	(57.15)		(107.95)	(260.35)	(28.45)	(11.18)	(190.50)	(22.35)	(16.00)	(35.05)	
20SM16072	VEE	1	0.562	4.12	2.06	0.63	2.81		5.12	10.25	1.62	0.56	9.00	1.25	1.13	1.75	
20SM16082	REG	(25.40)	(14.27)	(104.65)	(52.32)	(16.00)	(71.37)		(130.05)	(260.35)	(41.15)	(14.22)	(228.84)	(31.75)	(28.70)	(44.45)	
10SM9072	VEE	9/16	0.359	2.50	1.25	0.53	1.75		3.38	4.00	1.00	0.34	6.43	0.69	0.50	1.00	
10SM9082	REG	(14.29)	(9.12)	(63.50)	(31.75)	(13.46)	(44.45)		(85.85)	(101.60)	(25.40)	(8.64)	(163.56)	(17.53)	(12.70)	(25.40)	
10SM12072	VEE	3/4	0.516	3.00	1.50	0.62	2.25		4.25	10.25	1.12	0.44	7.50	0.88	0.63	1.38	
10SM12082	REG	(19.03)	(13.11)	(76.20)	(38.10)	(15.75)	(57.15)		(107.95)	(260.35)	(28.45)	(11.18)	(190.50)	(22.35)	(16.00)	(35.05)	
10SM16072	VEE	1	0.688	4.12	2.06	0.63	2.81		5.12	10.25	1.62	0.56	9.00	1.25	1.13	1.75	
10SM16082	REG	(25.40)	(17.48)	(104.65)	(52.32)	(16.00)	(71.37)		(130.05)	(260.35)	(41.15)	(14.22)	(228.84)	(31.75)	(28.70)	(44.45)	

3-Way / 2 on Pressure

20SM4073	VEE	1/4	0.125	2.00	1.00	0.38	1.63	1.19	2.63	3.00	0.75	0.22	5.00	0.62	0.38	0.75	See Figure 3
20SM4083	REG	(6.35)	(3.18)	(50.80)	(25.40)	(9.65)	(41.28)	(30.23)	(66.68)	(76.20)	(19.05)	(5.59)	(127.00)	(15.75)	(9.65)	(19.05)	
20SM6073	VEE	3/8	0.219	2.00	1.00	0.47	1.63	1.19	2.63	3.00	0.75	0.22	5.00	0.62	0.38	0.75	
20SM6083	REG	(9.53)	(5.56)	(50.80)	(25.40)	(11.94)	(41.28)	(30.23)	(66.68)	(76.20)	(19.05)	(5.59)	(127.00)	(15.75)	(9.65)	(19.05)	
20SM9073	VEE	9/16	0.312	2.50	1.25	0.53	2.38	1.75	3.63	4.00	1.00	0.34	6.51	0.69	0.50	1.00	
20SM9083	REG	(14.29)	(7.92)	(63.50)	(31.75)	(13.46)	(60.45)	(44.45)	(92.08)	(101.60)	(25.40)	(8.64)	(165.59)	(17.53)	(12.70)	(25.40)	
20SM12073	VEE	3/4	0.438	3.00	1.50	0.62	3.00	2.25	4.63	10.25	1.12	0.44	7.88	0.88	0.63	1.38	
20SM12083	REG	(19.05)	(11.13)	(76.20)	(38.10)	(15.75)	(76.20)	(57.15)	(117.48)	(260.35)	(28.45)	(11.18)	(200.03)	(22.35)	(16.00)	(35.05)	
20SM16073	VEE	1	0.562	4.12	2.06	0.63	3.75	2.81	5.88	10.25	1.62	0.56	9.75	1.25	1.13	1.75	
20SM16083	REG	(25.40)	(14.27)	(104.65)	(52.32)	(16.00)	(95.25)	(71.37)	(149.35)	(260.35)	(41.15)	(14.22)	(247.89)	(31.75)	(28.70)	(44.45)	
10SM9073	VEE	9/16	0.359	2.50	1.25	0.53	2.38	1.75	3.63	4.00	1.00	0.34	6.52	0.69	0.50	1.00	
10SM9083	REG	(14.29)	(9.12)	(63.50)	(31.75)	(13.46)	(60.45)	(44.45)	(92.08)	(101.60)	(25.40)	(8.64)	(165.59)	(17.53)	(12.70)	(25.40)	
10SM12073	VEE	3/4	0.516	3.00	1.50	0.62	3.00	2.25	4.63	10.25	1.12	0.44	7.88	0.88	0.63	1.38	
10SM12083	REG	(19.03)	(13.11)	(76.20)	(38.10)	(15.75)	(76.20)	(57.15)	(117.48)	(260.35)	(28.45)	(11.18)	(200.03)	(22.35)	(16.00)	(35.05)	
10SM16073	VEE	1	0.688	4.12	2.06	0.63	3.75	2.81	5.88	10.25	1.62	0.56	9.75	1.25	1.13	1.75	
10SM16083	REG	(25.40)	(17.48)	(104.65)	(52.32)	(16.00)	(95.25)	(71.37)	(149.35)	(260.35)	(41.15)	(14.22)	(247.89)	(31.75)	(28.70)	(44.45)	

G - Packing gland mounting hole drill size
G₁ - Bracket mounting hole size
Panel mounting drill size: 0.22" all valves.

* H Dimension is with stem in closed position.
All dimensions for reference only and subject to change.

For prompt service, Autoclave stock select products.
Consult factory.

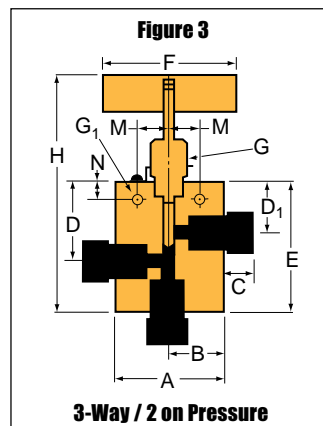
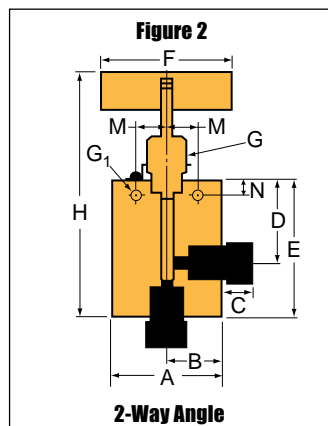

Catalog Number	Stem Type	Outside Diameter Tube	Orifice Diameter	Dimensions - inches (mm)												Block Thickness	Valve Pattern
				A	B	C	D	D ₁	E	F	G	G ₁	H*	M	N		

3-Way / 1 on Pressure

20SM4074	VEE	1/4	0.125	2.00	1.00	0.38	1.19		2.44	3.00	0.75	0.22	4.81	0.62	0.38	0.75	See Figure 4
20SM4084	REG	(6.35)	(3.18)	(50.80)	(25.40)	(9.65)	(30.23)		(61.90)	(76.20)	(19.05)	(5.59)	(122.25)	(15.75)	(9.65)	(19.05)	
20SM6074	VEE	3/8	0.219	2.00	1.00	0.47	1.19		2.44	3.00	0.75	0.22	4.81	0.62	0.38	0.75	
20SM6084	REG	(9.53)	(5.56)	(50.80)	(25.40)	(11.94)	(30.23)		(61.90)	(76.20)	(19.05)	(5.59)	(122.25)	(15.75)	(9.65)	(19.05)	
20SM9074	VEE	9/16	0.312	2.50	1.25	0.53	1.75		3.38	4.00	1.00	0.34	6.31	0.69	0.50	1.00	
20SM9084	REG	(14.29)	(7.92)	(63.50)	(31.75)	(13.46)	(44.45)		(85.85)	(101.60)	(25.40)	(8.64)	(160.56)	(17.53)	(12.70)	(25.40)	
20SM12074	VEE	3/4	0.438	3.00	1.50	0.62	2.25		4.25	10.25	1.12	0.44	7.50	0.88	0.63	1.38	
20SM12084	REG	(19.05)	(11.13)	(76.20)	(38.10)	(15.75)	(57.15)		(107.95)	(260.35)	(28.45)	(11.18)	(190.50)	(22.35)	(16.00)	(35.05)	
20SM16074	VEE	1	0.562	4.12	2.06	0.63	2.81		5.12	10.25	1.62	0.56	9.09	1.25	1.13	1.75	
20SM16084	REG	(25.40)	(14.27)	(104.65)	(52.32)	(16.00)	(71.37)		(130.05)	(260.35)	(41.15)	(14.22)	(231.13)	(31.75)	(28.70)	(44.45)	
10SM9074	VEE	9/16	0.359	2.50	1.25	0.53	1.75		3.38	4.00	1.00	0.34	6.31	0.69	0.50	1.00	
10SM9084	REG	(14.29)	(9.12)	(63.50)	(31.75)	(13.46)	(44.45)		(85.85)	(101.60)	(25.40)	(8.64)	(160.56)	(17.53)	(12.70)	(25.40)	
10SM12074	VEE	3/4	0.516	3.00	1.50	0.62	2.25		4.25	10.25	1.12	0.44	7.50	0.88	0.63	1.38	
10SM12084	REG	(19.03)	(13.11)	(76.20)	(38.10)	(15.75)	(57.15)		(107.95)	(260.35)	(28.45)	(11.18)	(190.50)	(22.35)	(16.00)	(35.05)	
10SM16074	VEE	1	0.688	4.12	2.06	0.63	2.81		5.12	10.25	1.62	0.56	9.09	1.25	1.13	1.75	
10SM16084	REG	(25.40)	(17.48)	(104.65)	(52.32)	(16.00)	(71.37)		(130.05)	(260.35)	(41.15)	(14.22)	(231.13)	(31.75)	(28.70)	(44.45)	

2-Way Angle / Replaceable Seat

20SM4872	VEE	1/4	0.125	2.00	1.00	0.38	1.19	2.13	2.25	3.00	0.75	0.22	5.75	0.62	0.38	0.75	See Figure 5
20SM4882	REG	(6.35)	(3.18)	(50.80)	(25.40)	(9.65)	(30.23)	(53.98)	(57.15)	(76.20)	(19.05)	(5.59)	(146.05)	(15.75)	(9.65)	(19.05)	
20SM6872	VEE	3/8	0.219	2.00	1.00	0.47	1.19	2.13	2.25	3.00	0.75	0.22	5.75	0.62	0.38	0.75	
20SM6882	REG	(9.53)	(5.56)	(50.80)	(25.40)	(11.94)	(30.23)	(53.98)	(57.15)	(76.20)	(19.05)	(5.59)	(146.05)	(15.75)	(9.65)	(19.05)	
20SM9872	VEE	9/16	0.312	2.50	1.25	0.53	1.75	2.50	3.13	4.00	1.00	0.34	7.34	0.69	0.50	1.00	
20SM9882	REG	(14.29)	(7.92)	(63.50)	(31.75)	(13.46)	(44.45)	(63.50)	(79.38)	(101.60)	(25.40)	(8.64)	(186.68)	(17.53)	(12.70)	(25.40)	
20SM12872	VEE	3/4	0.438	3.00	1.50	0.62	2.25	3.44	4.25	10.25	1.12	0.44	9.00	0.88	0.63	1.38	
20SM12882	REG	(19.05)	(11.13)	(76.20)	(38.10)	(15.75)	(57.15)	(87.38)	(107.95)	(260.35)	(28.45)	(11.18)	(228.60)	(22.35)	(16.00)	(35.05)	
20SM16872	VEE	1	0.562	4.12	2.06	0.63	2.69	4.38	5.25	10.25	1.62	0.56	11.00	1.25	1.13	1.75	
20SM16882	REG	(25.40)	(14.27)	(104.65)	(52.32)	(16.00)	(68.33)	(111.13)	(133.35)	(260.35)	(41.15)	(14.22)	(279.64)	(31.75)	(28.70)	(44.45)	
10SM9872	VEE	9/16	0.359	2.50	1.25	0.53	1.75	2.50	3.38	4.00	1.00	0.34	7.34	0.69	0.50	1.00	
10SM9882	REG	(14.29)	(9.12)	(63.50)	(31.75)	(13.46)	(44.45)	(63.50)	(85.85)	(101.60)	(25.40)	(8.64)	(186.68)	(17.53)	(12.70)	(25.40)	
10SM12872	VEE	3/4	0.516	3.00	1.50	0.62	2.25	3.44	4.25	10.25	1.12	0.44	9.00	0.88	0.63	1.38	
10SM12882	REG	(19.03)	(13.11)	(76.20)	(38.10)	(15.75)	(57.15)	(87.38)	(107.95)	(260.35)	(28.45)	(11.18)	(228.60)	(22.35)	(16.00)	(35.05)	
10SM16872	VEE	1	0.688	4.12	2.06	0.63	2.69	4.38	5.25	10.25	1.62	0.56	11.00	1.25	1.13	1.75	
10SM16882	REG	(25.40)	(17.48)	(104.65)	(52.32)	(16.00)	(68.33)	(111.13)	(133.35)	(260.35)	(41.15)	(14.22)	(279.64)	(31.75)	(28.70)	(44.45)	

G - Packing gland mounting hole drill size
G₁ - Bracket mounting hole size
Panel mounting drill size: 0.22" all valves.

* H Dimension is with stem in closed position.
All dimensions for reference only and subject to change.

For prompt service, Autoclave stock select products.
Consult factory.

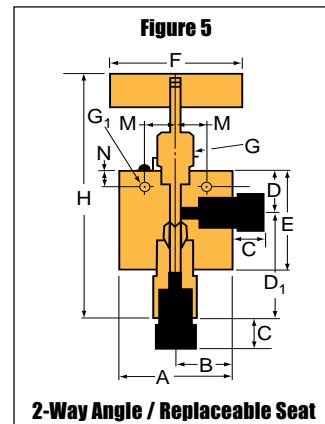
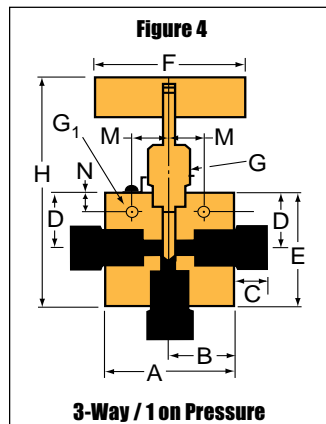

Catalog Number	Stem Type	Outside Diameter Tube	Orifice Diameter	Dimensions - inches (mm)												Block Thickness	Valve Pattern
				A	B	C	D	D ₁	E	F	G	G ₁	H*	M	N		

3-Way Angle / 2-Stem Manifold

20SM4075	VEE	1/4	0.125	2.00	1.00	0.38	1.69	1.19	3.38	3.00	0.75	0.22	8.13	0.62	0.38	0.75	See Figure 6
20SM4085	REG	(6.35)	(3.18)	(50.80)	(25.40)	(9.65)	(42.85)	(30.15)	(85.73)	(76.20)	(19.05)	(5.59)	(206.38)	(15.75)	(9.65)	(19.05)	
20SM6075	VEE	3/8	0.219	2.00	1.00	0.47	1.69	1.19	3.38	3.00	0.75	0.22	8.13	0.62	0.38	0.75	
20SM6085	REG	(9.53)	(5.56)	(50.80)	(25.40)	(11.94)	(42.85)	(30.15)	(85.73)	(76.20)	(19.05)	(5.59)	(206.38)	(15.75)	(9.65)	(19.05)	
20SM9075	VEE	9/16	0.312	2.50	1.25	0.53	2.56	1.75	5.13	4.00	1.00	0.34	11.31	0.69	0.50	1.00	
20SM9085	REG	(14.29)	(7.92)	(63.50)	(31.75)	(13.46)	(65.07)	(44.45)	(130.18)	(101.60)	(25.40)	(8.64)	(287.56)	(17.53)	(12.70)	(25.40)	
20SM12075	VEE	3/4	0.438	3.00	1.50	0.62	3.25	2.25	6.50	10.25	1.12	0.44	13.00	0.88	0.63	1.38	
20SM12085	REG	(19.05)	(11.13)	(76.20)	(38.10)	(15.75)	(82.55)	(57.15)	(165.10)	(260.35)	(28.45)	(11.18)	(330.20)	(22.35)	(16.00)	(35.05)	
20SM16075	VEE	1	0.562	4.12	2.06	0.63	3.75	2.81	7.50	10.25	1.62	0.56	15.44	1.25	1.13	1.75	
20SM16085	REG	(25.40)	(14.27)	(104.65)	(52.32)	(16.00)	(95.25)	(71.37)	(190.50)	(260.35)	(41.15)	(14.22)	(292.42)	(31.75)	(28.70)	(44.45)	
10SM9075	VEE	9/16	0.359	2.50	1.25	0.53	2.56	1.75	5.13	4.00	1.00	0.34	11.31	0.69	0.50	1.00	
10SM9085	REG	(14.29)	(9.12)	(63.50)	(31.75)	(13.46)	(65.07)	(44.45)	(130.18)	(101.60)	(25.40)	(8.64)	(287.56)	(17.53)	(12.70)	(25.40)	
10SM12075	VEE	3/4	0.516	3.00	1.50	0.62	3.25	2.25	6.50	10.25	1.12	0.44	13.00	0.88	0.63	1.38	
10SM12085	REG	(19.03)	(13.11)	(76.20)	(38.10)	(15.75)	(82.55)	(57.15)	(165.10)	(260.35)	(28.45)	(11.18)	(330.20)	(22.35)	(16.00)	(35.05)	
10SM16075	VEE	1	0.688	4.12	2.06	0.63	3.75	2.81	7.50	10.25	1.62	0.56	15.44	1.25	1.13	1.75	
10SM16085	REG	(25.40)	(17.48)	(104.65)	(52.32)	(16.00)	(95.25)	(71.37)	(190.50)	(260.35)	(41.15)	(14.22)	(392.42)	(31.75)	(28.70)	(44.45)	

G - Packing gland mounting hole drill size
G₁ - Bracket mounting hole size
Panel mounting drill size: 0.22" all valves.

* H Dimension is with stem in closed position.
All dimensions for reference only and subject to change.

**For prompt service, Autoclave
stock select products.
Consult factory.**

