

ATKOMATIC

 **CIRCLE SEAL CONTROLS, INC.**
A division of CIRCOR International, Inc.

15,800 Series

Stainless Steel, Semi-Direct Lift, 0 to 1500 PSIG
Medium Pressure Valve Configurable for Variety of Fluid Applications

Features

- Stainless steel construction on all wetted parts – 316 for barstock parts and CF8M for cast parts.
- Plunger material is 416 stainless that is treated for increased corrosion resistance
- Semi-direct lift action for operation down to zero pressure differential
- Normally Closed operation
- Operation up to 1500 psi
- Media temperatures from -423° F to +500° F
- Will handle fluids with viscosity up to 150 SUS
- Suitable for use with wide variety of fluid including: air, gasses, liquids, hydraulic fluids, steam, cryogenic fluids, and corrosive fluids
- Optional pilot and piston seat materials of Teflon®, Kel-F, Buna-N, Viton®, EPR, or 316 stainless steel depending on fluid type and pressure
- Body seal materials of Teflon®, Viton®, Buna-N, or EPR
- Pipe sizes from 1/4" through 1" NPT
- British BSPT ports are available
- Full ported valves - Cv from 1.1 through 12.5
- Removable 316 SS body inserts (stainless steel trim)
- Class H coils standard
- Coils housings available in NEMA 1 (standard), NEMA 4 (waterproof), NEMA 7 (explosion-proof for hazardous locations), and combination NEMA 4 and 7
- Manual opening device is available as an options
- Valve position indicator option is available

Operational Pressures (No minimum pressure differential)

Gases		Liquids to 40 SUS		Liquids over 40 SUS		Steam	
A.C.	D.C.	A.C.	D.C.	A.C.	D.C.	A.C.	D.C.
1500	1500	1500	1000	1500	1000	200	200

NOTE: Rubber seats are limited to 500 psi.

2301 Wardlow Circle, P.O. Box 3300
Corona, California 92878
tel 909-270-6200
fax 909-270-6201
www.circle-seal.com
am_sales@circle-seal.com
ind_sales@circle-seal.com

15,800 Series

Dimensions, Shipping Weights, and C_v Flow Factors

15,800 Series Normally Closed Stainless Steel

Catalog Num. Prefix	Pipe Size	Main Seat Orifice Dia	X	Y	Z	Shipping Weight (lbs.)	C _v
15800	1/4"	3/8"	7 3/8"	6 1/2"	3"	7	1.1
15810	3/8"	3/8"	7 3/8"	6 1/2"	3"	7	2.5
15820	1/2"	3/4"	8 1/4"	7 1/8"	4 5/8"	9	5.1
15830	3/4"	3/4"	8 1/4"	7 1/8"	4 5/8"	9	7.5
15840	1"	1"	9 3/16"	7 11/16"	5 1/4"	15	12.5

15840 1" Valve – (shown with a NEMA 1 coil housing and a metal pilot seat)

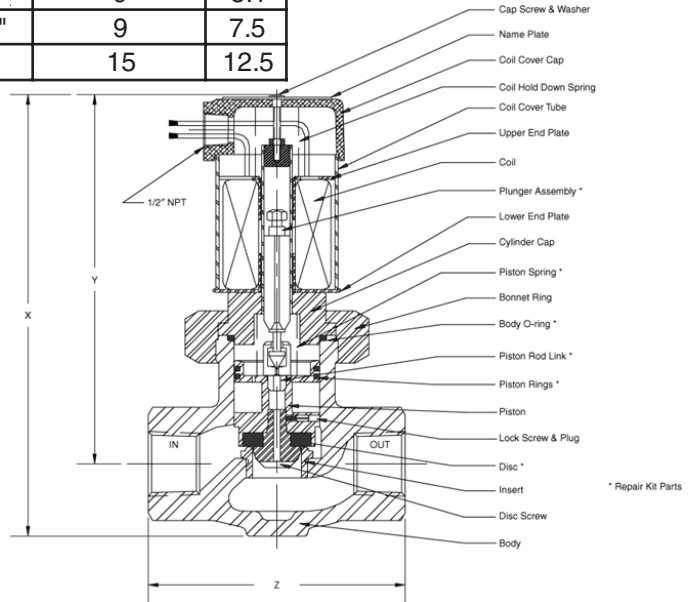

How to Order

158 x 0 x - x x H x x x x x x x

CONNECTION SIZE

0 1/4" Pipe	1 3/8" Pipe
2 1/2" Pipe	3 3/4" Pipe
4 1" Pipe	5 1 1/4" Pipe
6 1 1/2" Pipe	

VOLTAGE AC/60 Hz

0 AC/50 Hz or DC Voltage	
1 24 VAC	2 100 VAC
3 115 VAC	4 200 VAC
5 230 VAC	6 460 VAC

VOLTAGE AC/50 Hz

0 AC/60 Hz or DC Voltage	
1 24 VAC	2 110 VAC
3 220 VAC	4 380 VAC

VOLTAGE DC

0 AC Voltage	
1 12 VDC	2 24 VDC
3 32 VDC	4 72 VDC
5 125 VDC	6 250 VDC

CONNECTION TYPE

P NPT	J British Pipe Thread
-------	-----------------------

MAX. OPERATING PRESSURE (psig)

A 100	E 250	I 700
B 125	F 300	J 1000
C 150	G 350	K 1200
D 200	H 500	L 1500

OPTIONS

P Position Indicator
M Manual Opening

COIL HOUSING

E Explosion-proof
S Standard
W Waterproof
C Combined Water- & Explosion-proof

FLUID MEDIA TYPE

1 Gas	4 Steam
2 Liquid up to 40 SUS	5 Cryogenic
3 Liquid from 41 SUS to 150 SUS	

SEAL MATERIAL

A Teflon®	B Buna-N
C Viton®	D EPR

SEAT/PILOT MATERIAL

A TFE pilot & TFE disc
B Buna pilot & Buna disc
C Viton® pilot & Viton® disc
D EPR pilot & EPR disc
E Kel-F pilot & Kel-F disc
F Metal pilot & Metal disc
G Metal pilot & TFE disc
H Metal pilot & Buna disc
I Metal pilot & Viton® disc
J Metal pilot & EPR disc
K Metal pilot & Kel-F disc